

DISASSEMBLY

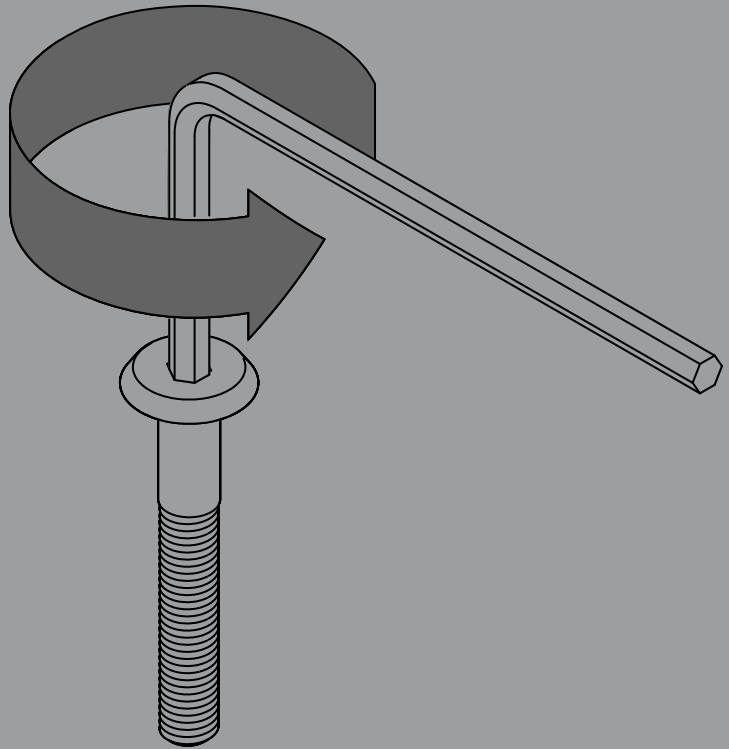

HAY

All the furniture in this instruction manual is ecolabelled and designed to be long-lasting products made to endure years to come. The furniture is 100% recyclable and parts can be fully separated and recycled. All parts can be delivered to a suitable recycling facility.

- TABLE OF CONTENTS -

ARBOUR ECO	6
CHISEL LOUNGE CHAIR	8
AAC 08	9
AAC 12	10
AAC 14	11
AAC 16	12
AAC 18	13
AAC 20	14
AAC 22	15
AAC 24	16
AAC 26	17
AAC 42	18
AAC 50	19
AAC 52	20
AAS 32	21
AAS 38	22
SOFT EDGE 40 CHAIR	23
SOFT EDGE 40 CHAIR WITH UPHOLSTERY	24
SOFT EDGE 50 SLED	25
SOFT EDGE 50 SLED WITH UPHOLSTERY	26
SOFT EDGE 60 CHAIR	27
SOFT EDGE 60 CHAIR WITH UPHOLSTERY	28
SOFT EDGE 70 STOOL	29
SOFT EDGE 72 STOOL	30
SOFT EDGE 80 BAR STOOL	31
SOFT EDGE 82 BAR STOOL	32
SOFT EDGE 90 BAR STOOL	33
SOFT EDGE 90 BAR STOOL WITH UPHOLSTERY	34
SOFT EDGE 100 LOUNGE	35
SOFT EDGE 100 LOUNGE WITH UPHOLSTERY	36

- TABLE OF CONTENTS -

RESULT CHAIR	37
RESULT CHAIR WITH UPHOLSTERY	38
RESULT ARMCHAIR	39
RESULT ARMCHAIR WITH UPHOLSTERY	40
REVOLT CHAIR	41
CPH 10	42
CPH 25	43
CPH 30	44
CPH 30 EXTENDABLE	45
CPH 90	46
CPH 190	47
CPH DEUX 210	48
CPH DEUX 215	49
CPH DEUX 220	50
CPH DEUX 250	51
PASTIS TABLE	52
TRIANGLE LEG BENCH	53
TRIANGLE LEG TABLE	54
BOA TABLE	55

1. Remove the cushions.
2. Turn the sofa upside down and separate the base from the frame by unscrewing all the screws

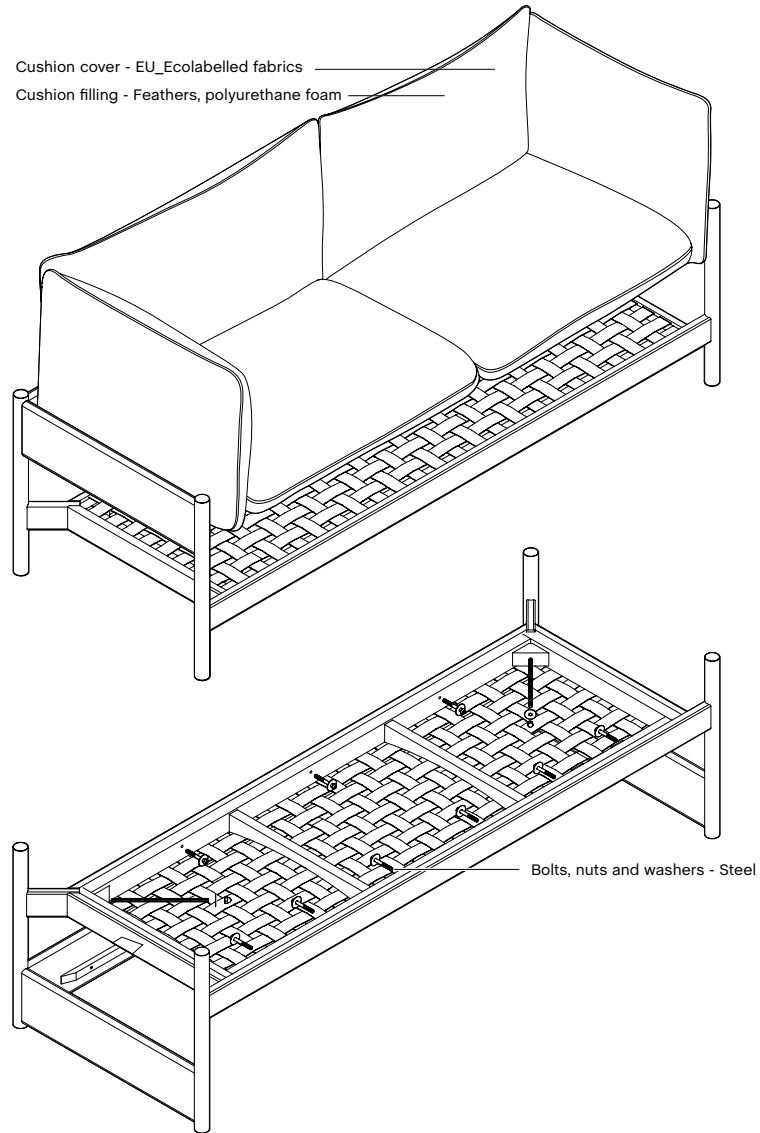

3. Remove the webbing base by lifting it up.
4. Unscrew all the screws to remove the steel profile and the wood profile from the frame.

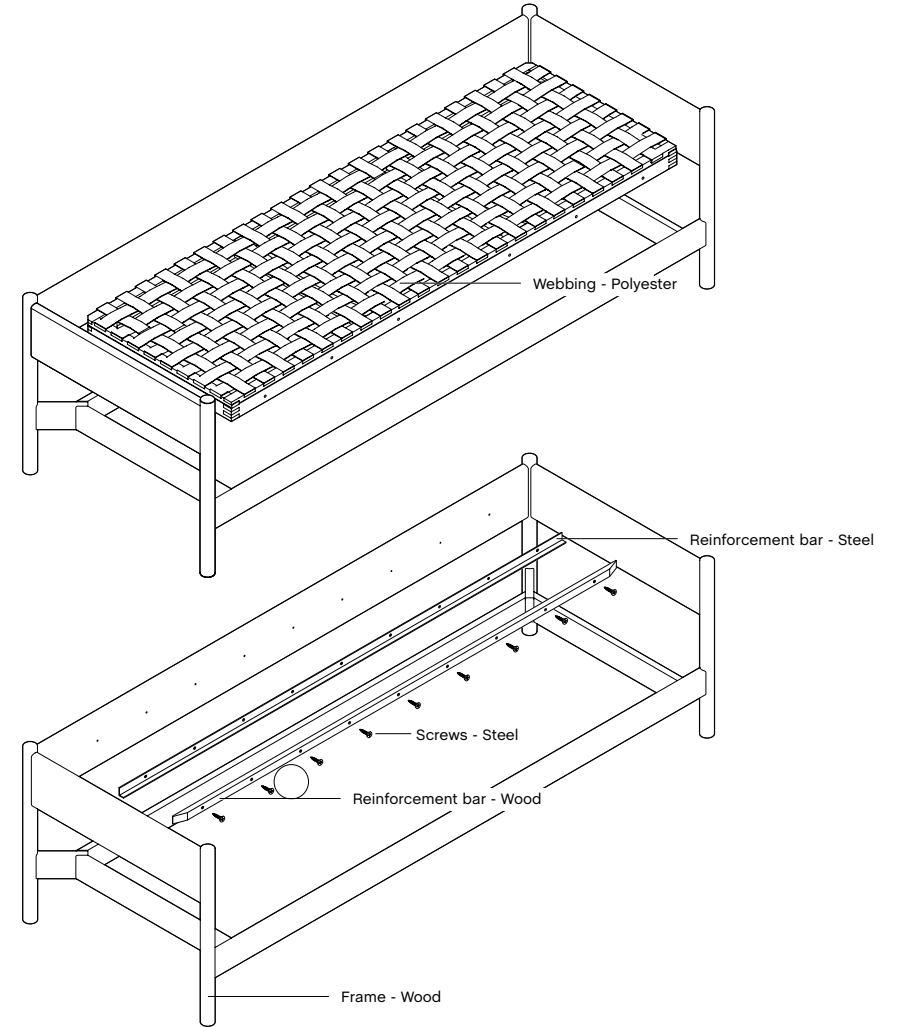

- CHISEL LOUNGE CHAIR -

1. Turn the table upside down.
2. Unscrew all the screws holding the legs and crossbar.
3. Unscrew the gliders from the legs.

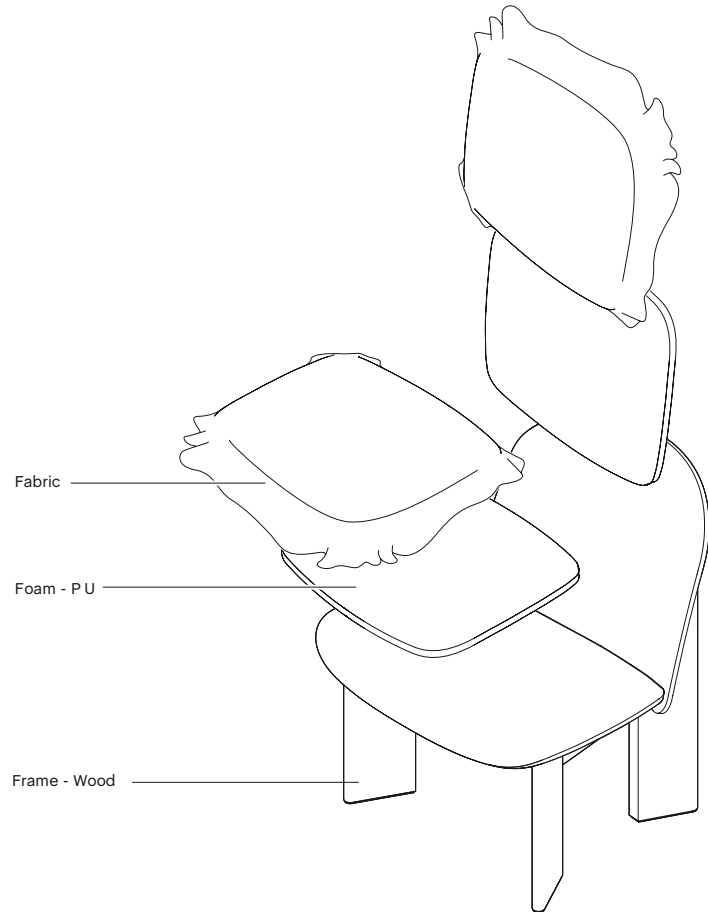

- AAC 08 -

1. Turn the chair upside down.
2. Remove all the bushings from the bottom of the seat.
3. Remove the gliders from the legs.
4. Separate the base from the seat.

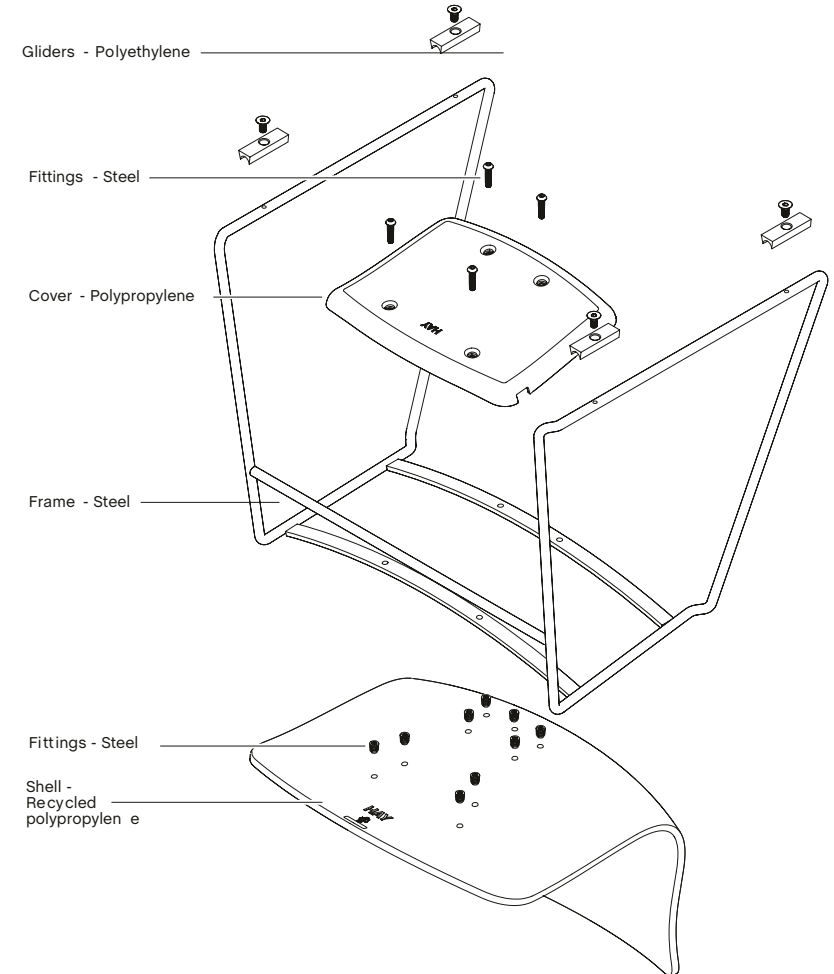

1. Turn the chair upside down.
2. Remove all the bushings from the bottom of the seat.
3. Remove the gliders from the legs.
4. Separate the base from the seat.

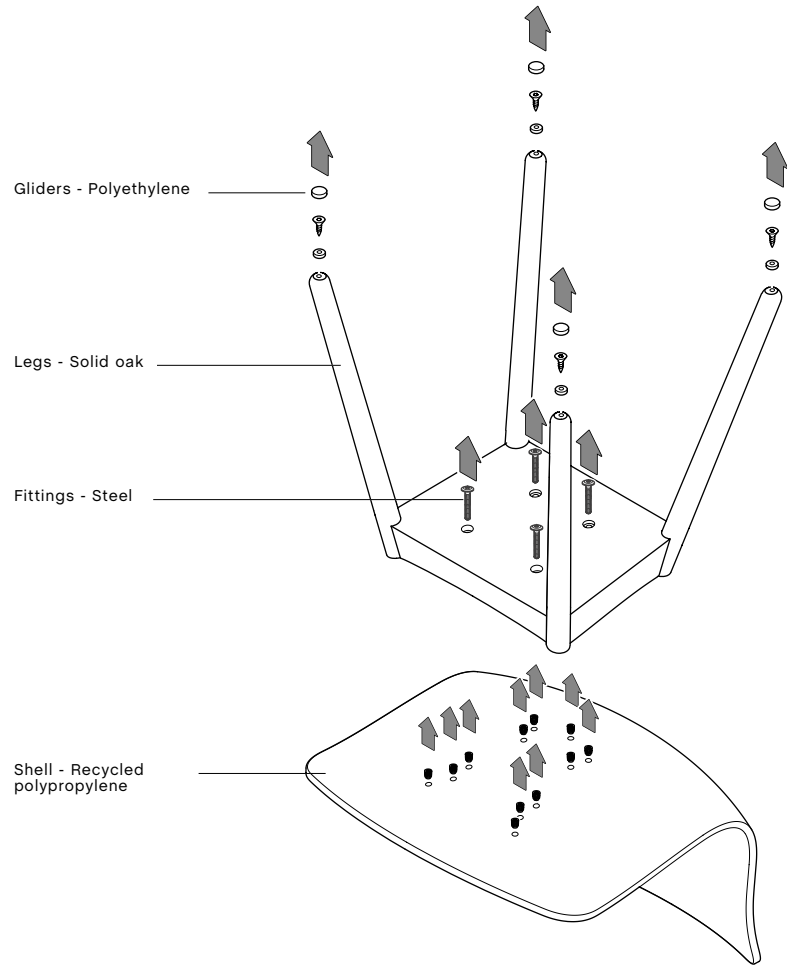

1. Turn the chair upside down.
2. Remove all the bushings from the bottom of the seat.
3. Remove the wheels from the legs.
4. Separate the base from the seat.

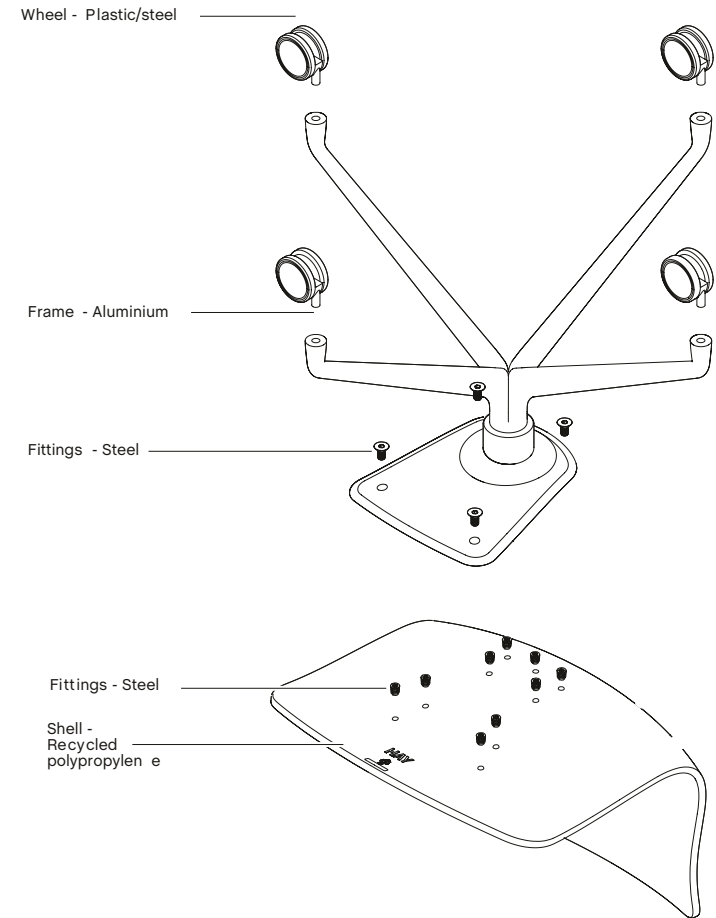

1. Turn the chair upside down.
2. Remove all the bushings from the bottom of the seat.
3. Remove the gliders from the legs.
4. Separate the base from the seat.

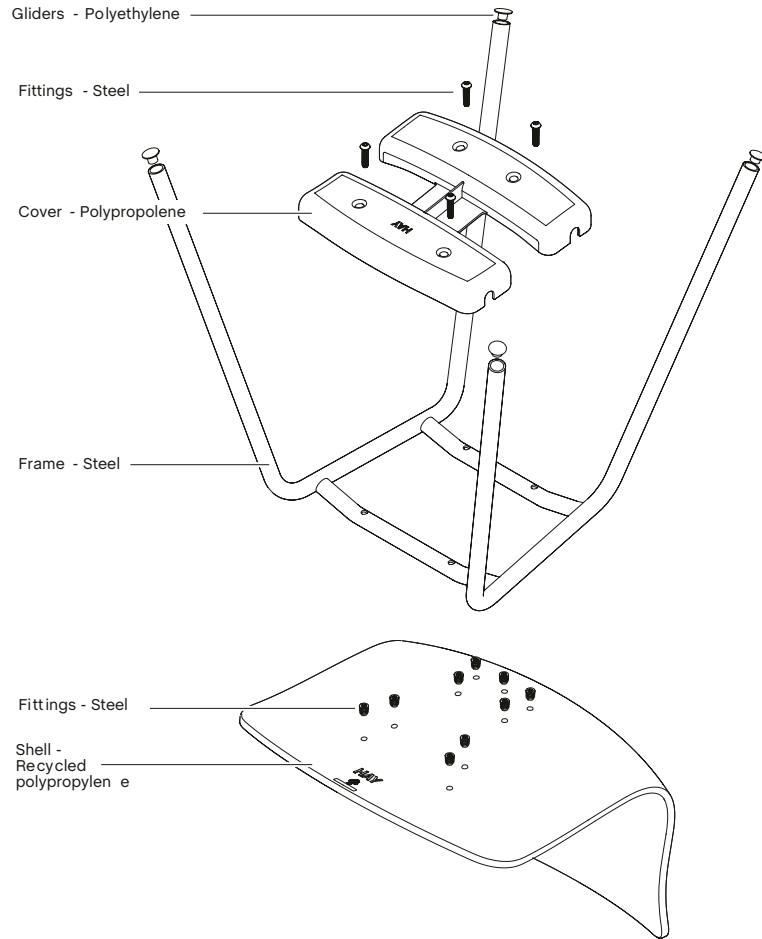

1. Turn the chair upside down.
2. Remove all the bushings from the bottom of the seat.
3. Remove the gliders from the legs.
4. Separate the base from the seat.

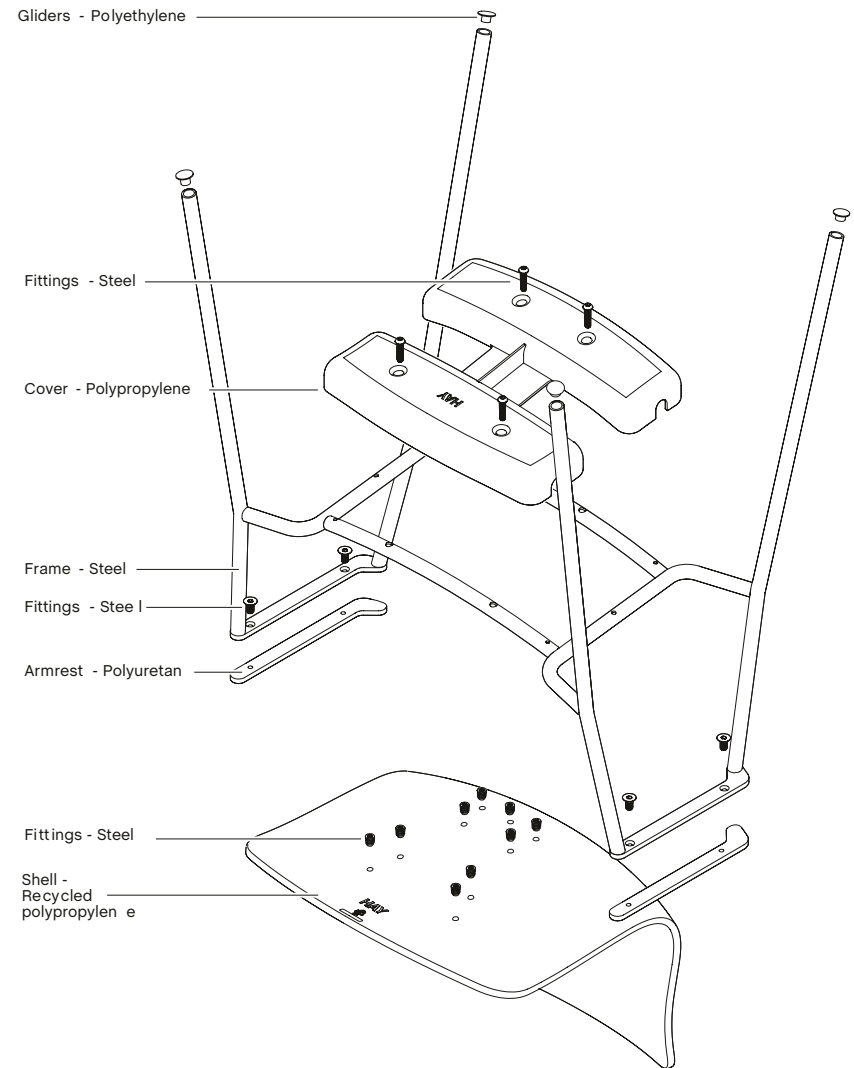

1. Turn the chair upside down.
2. Remove all the bushings from the bottom of the seat.
3. Remove the gliders from the legs.
4. Separate the base from the seat.

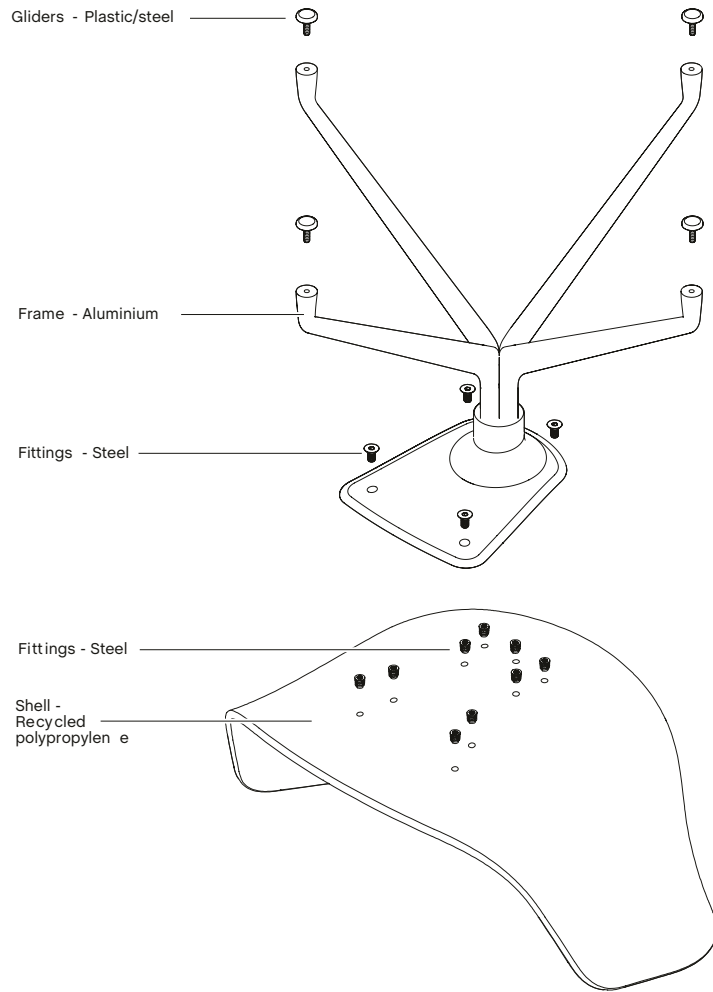

1. Turn the chair upside down.
2. Remove all the bushings from the bottom of the seat.
3. Remove the gliders from the legs.
4. Separate the base from the seat.

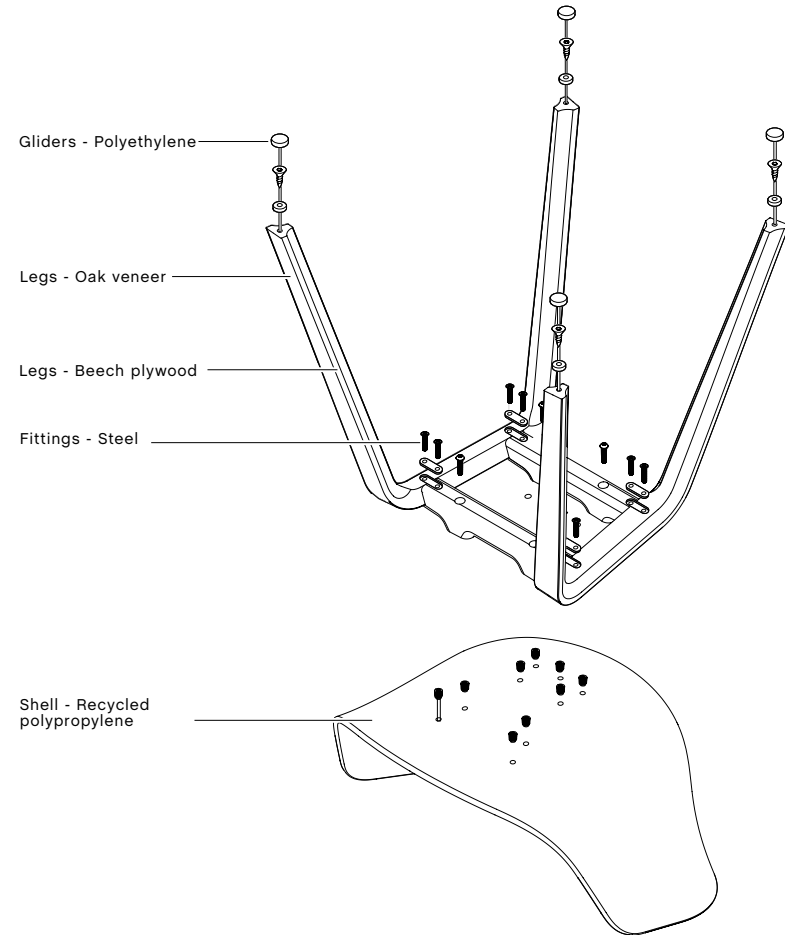

1. Turn the chair upside down.
2. Remove all the bushings from the bottom of the seat.
3. Remove the wheels from the legs.
4. Separate the base from the seat.

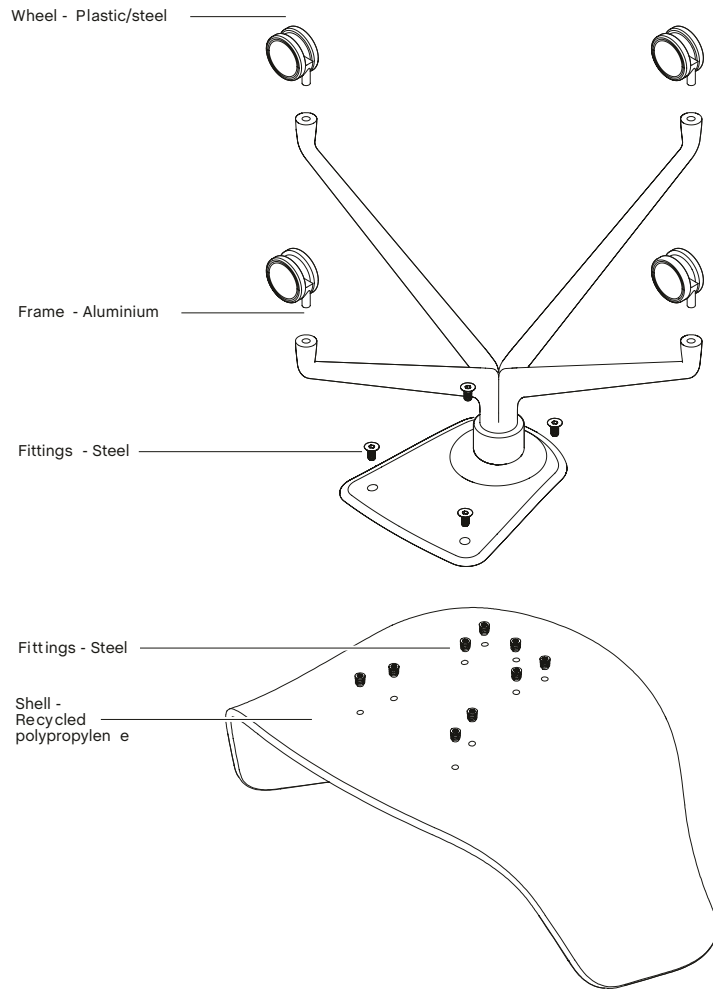

1. Turn the chair upside down.
2. Remove all the bushings from the bottom of the seat.
3. Remove the gliders from the legs.
4. Separate the base from the seat.

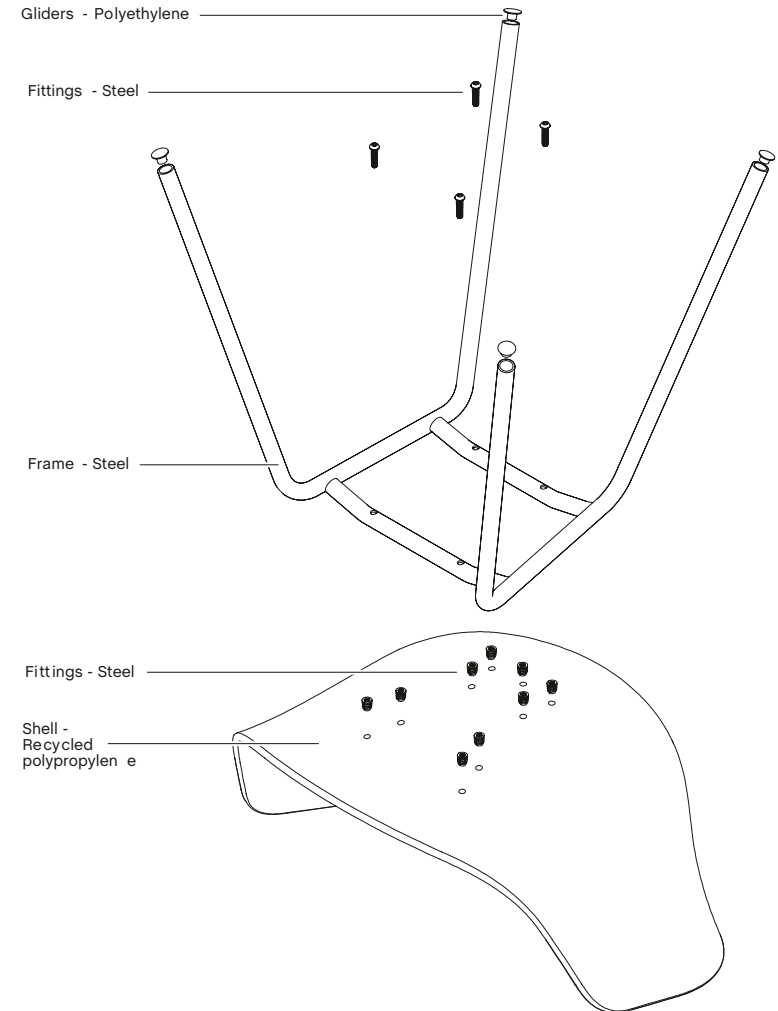

1. Turn the chair upside down.
2. Remove all the bushings from the bottom of the seat.
3. Remove the gliders from the legs.
4. Separate the base from the seat.

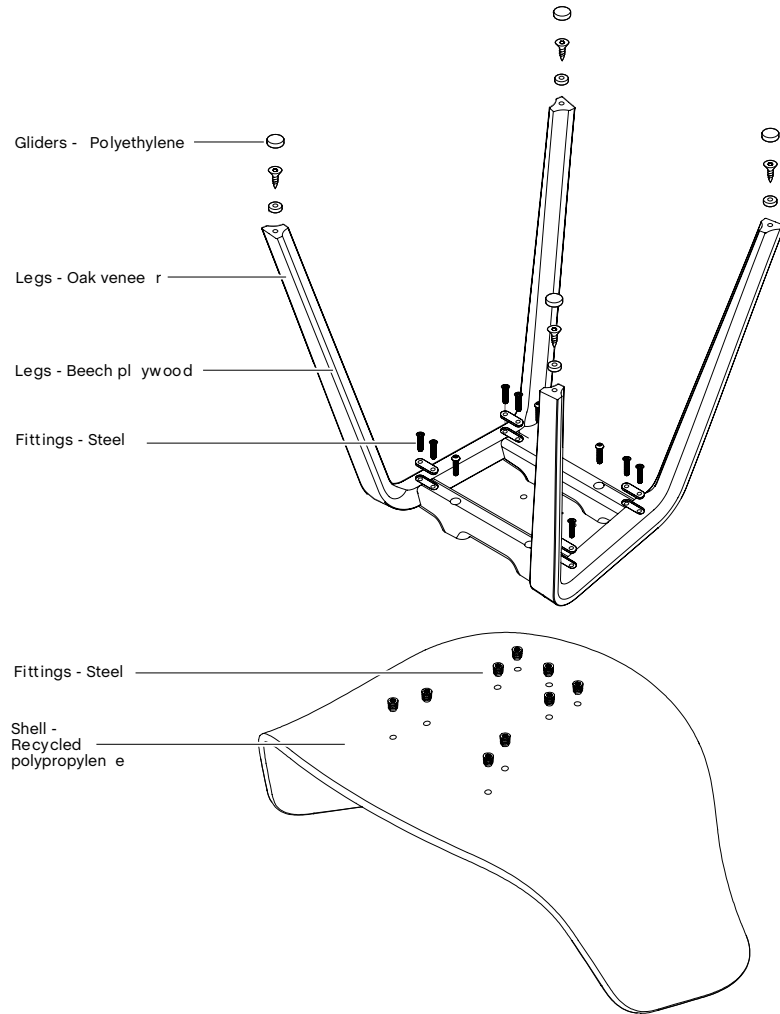

1. Turn the chair upside down.
2. Remove all the bushings from the bottom of the seat.
3. Remove the wheels from the legs.
4. Separate the base from the seat.

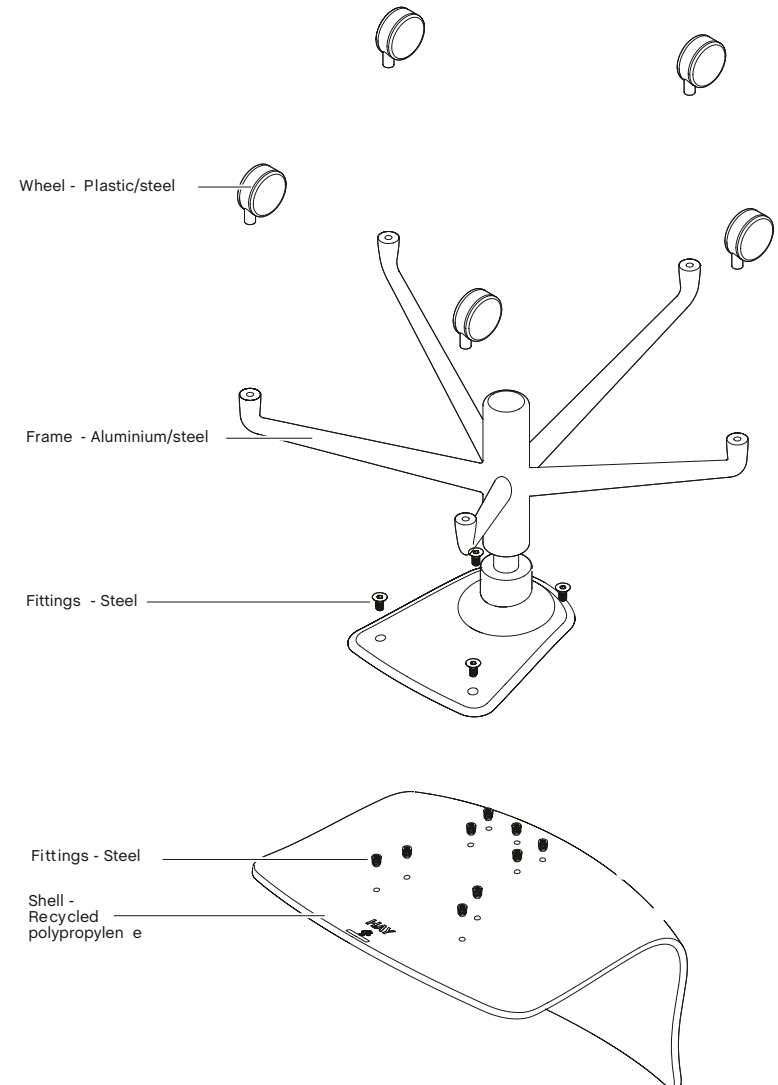

1. Turn the chair upside down.
2. Remove all the bushings from the bottom of the seat.
3. Remove the wheels from the legs.
4. Separate the base from the seat.

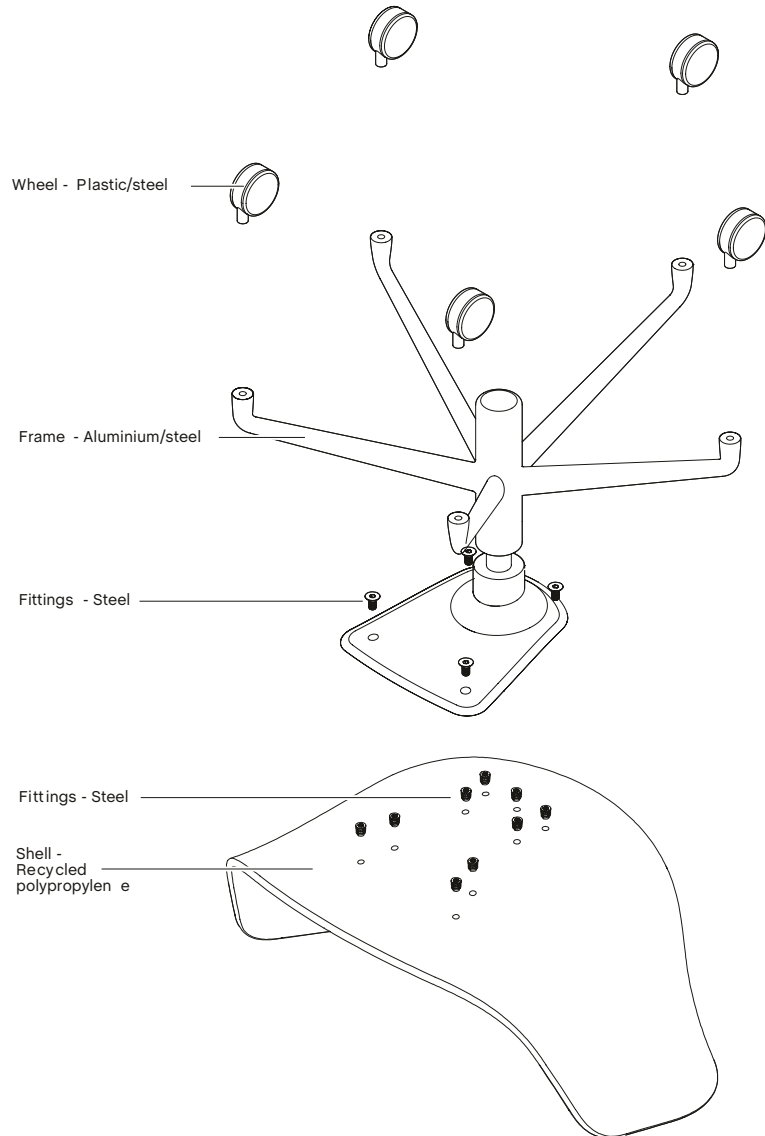

1. Turn the chair upside down.
2. Remove all the bushings from the bottom of the seat.
3. Remove the gliders and the footrest from the legs.
4. Separate the base from the seat.

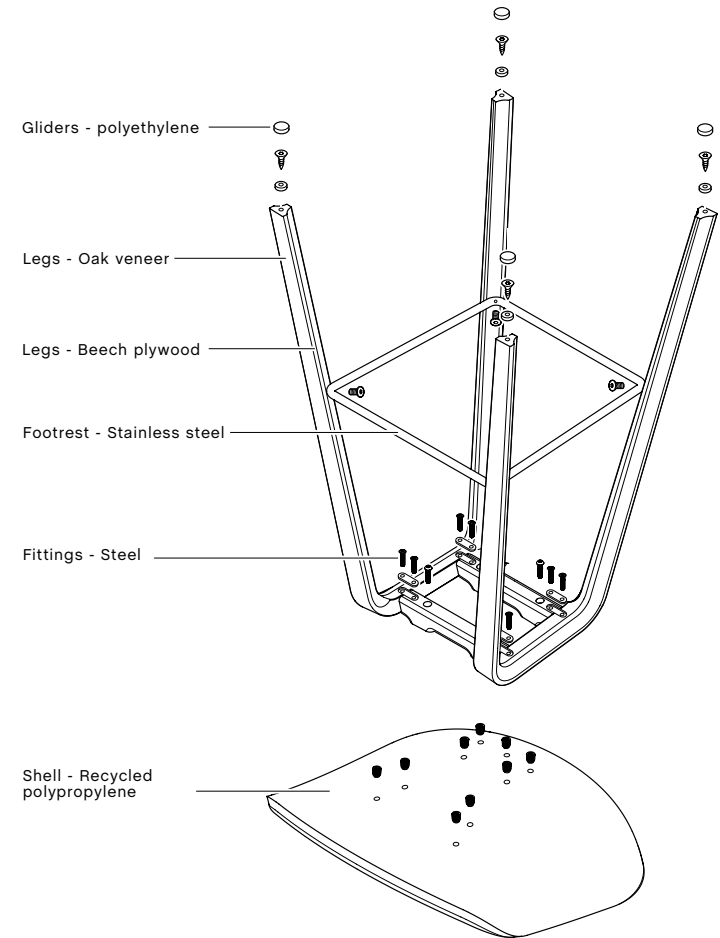

1. Turn the chair upside down.
2. Remove all the bushings from the bottom of the seat.
3. Remove the gliders and the footrest from the legs.
4. Separate the base from the seat.

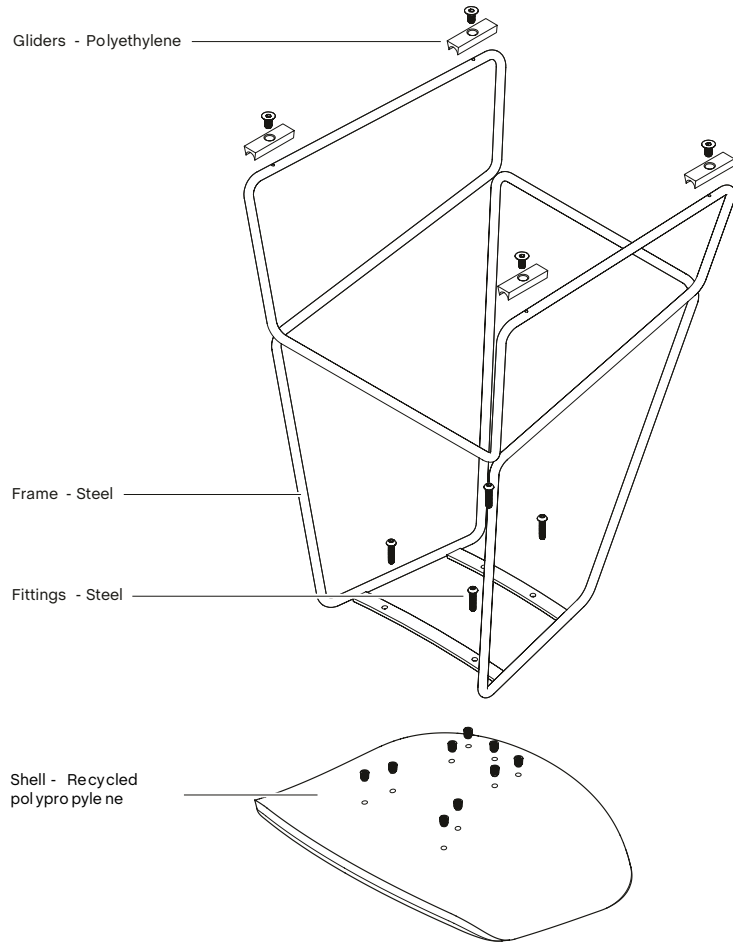

1. Hold the seat and backrest while unscrewing the rivets, using a power drill with a 10mm bit.
2. Pull out the gliders from the legs.
3. Turn the chair upside down and drill out the rivets holding the cover.

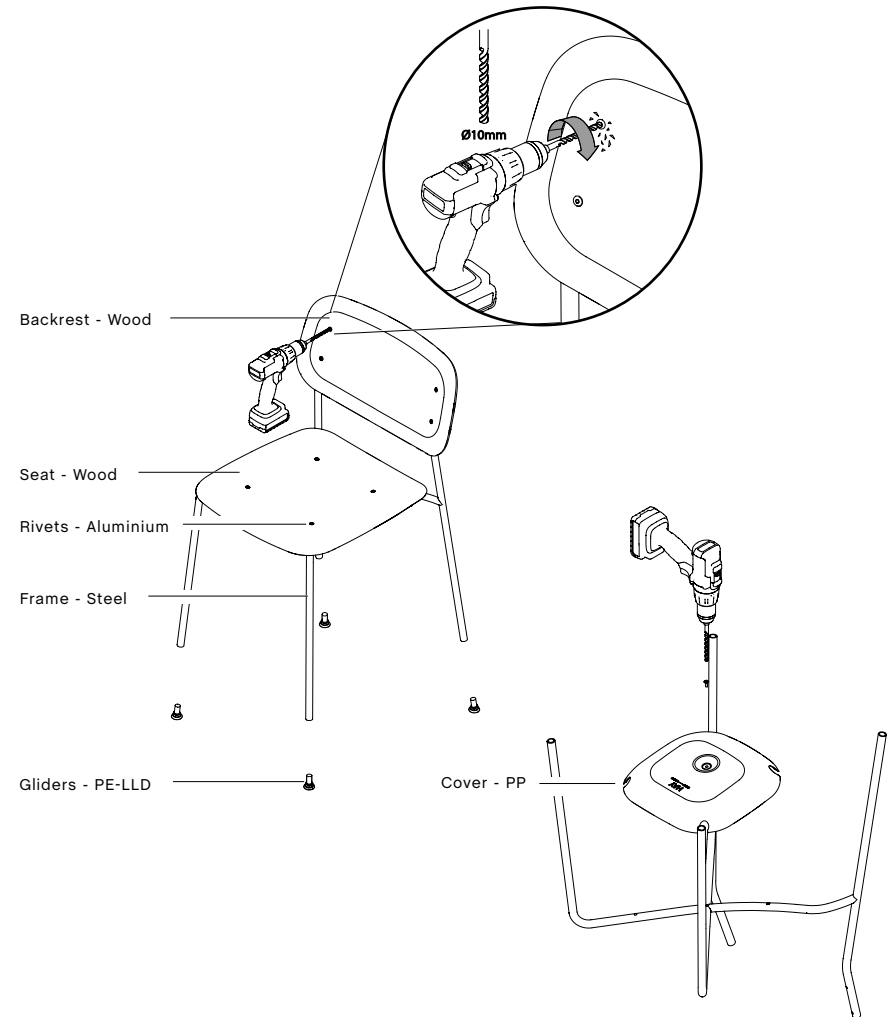

- SOFT EDGE 40 CHAIR WITH UPHOLSTERY -

1. Hold the seat and backrest while unscrewing the rivets, using a power drill with a 10mm bit.
2. Pull out the gliders from the legs.
3. Turn the chair upside down and drill out the rivets holding the cover.
4. Remove the upholstery and the foam from the wooden shell.

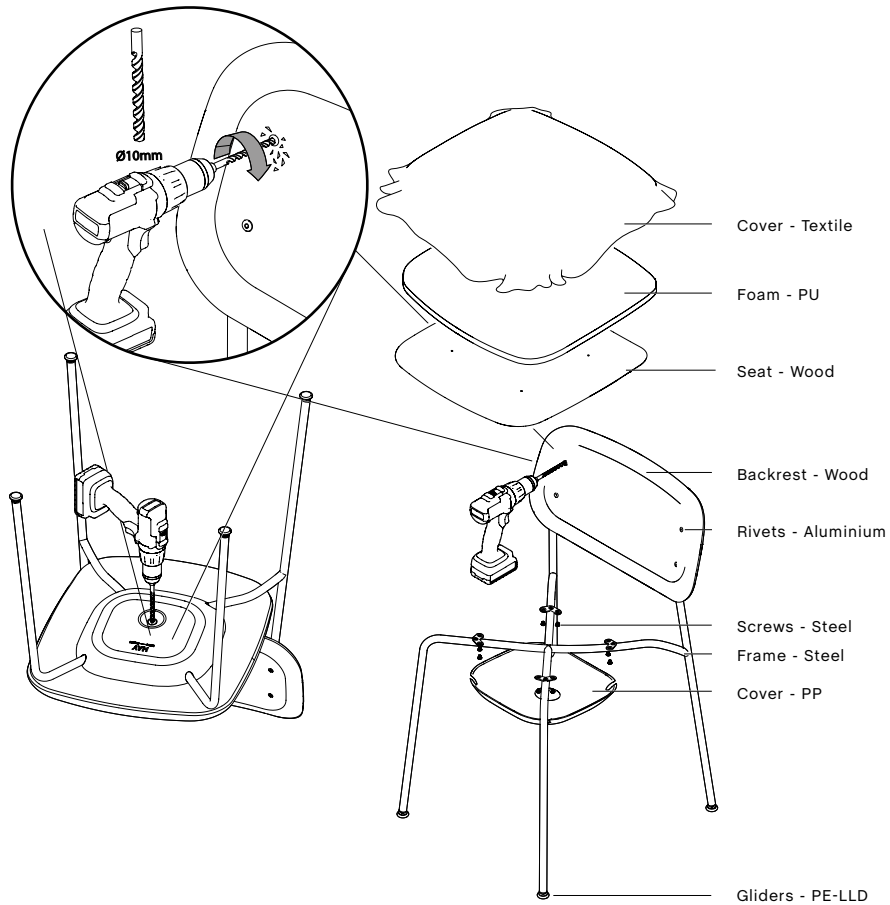

- SOFT EDGE 50 SLED -

1. Hold the seat and backrest while unscrewing the rivets, using a power drill with a 10mm bit.
2. Unscrew the gliders from the sled legs.
3. Turn the chair upside down and drill out the rivets holding the cover.

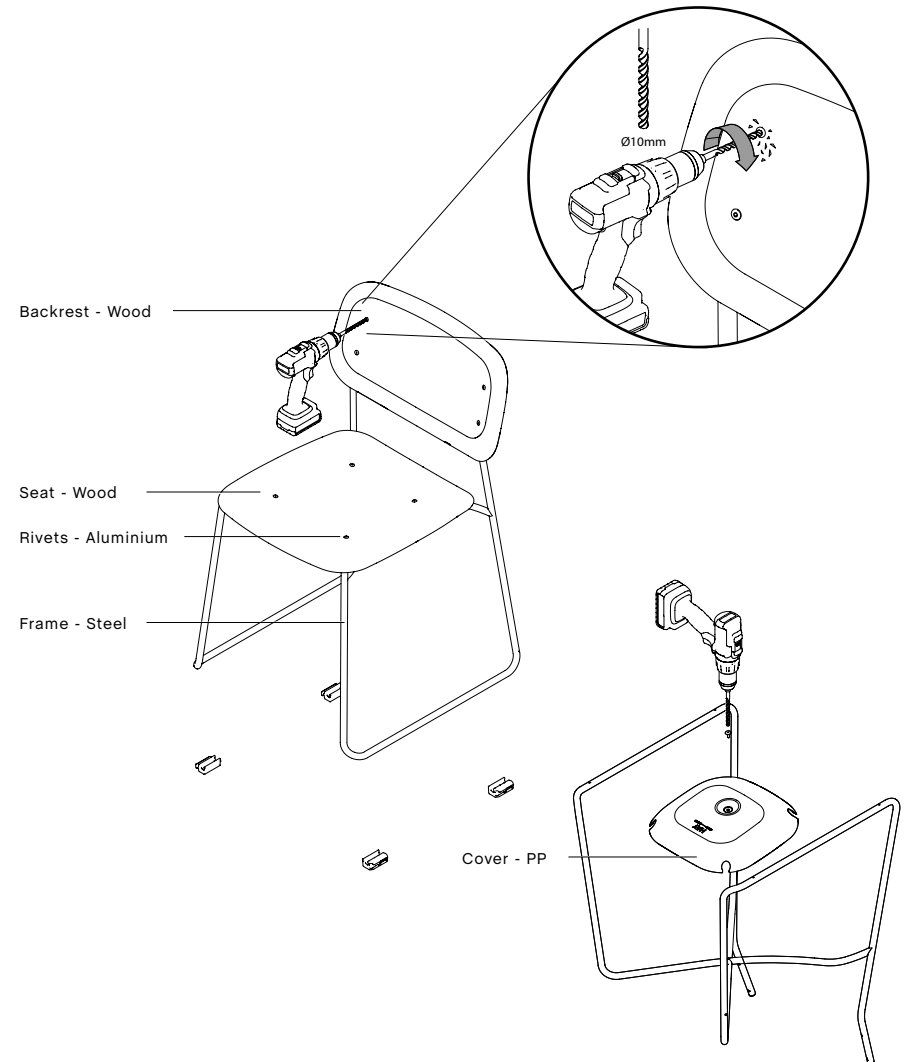

- SOFT EDGE 50 SLED WITH UPHOLSTERY -

1. Hold the seat and backrest while unscrewing the rivets, using a power drill with a 10mm bit.
2. Unscrew the gliders from the sled legs.
3. Turn the chair upside down and drill out the rivets holding the cover.
4. Remove the upholstery and the foam from the wooden shell.

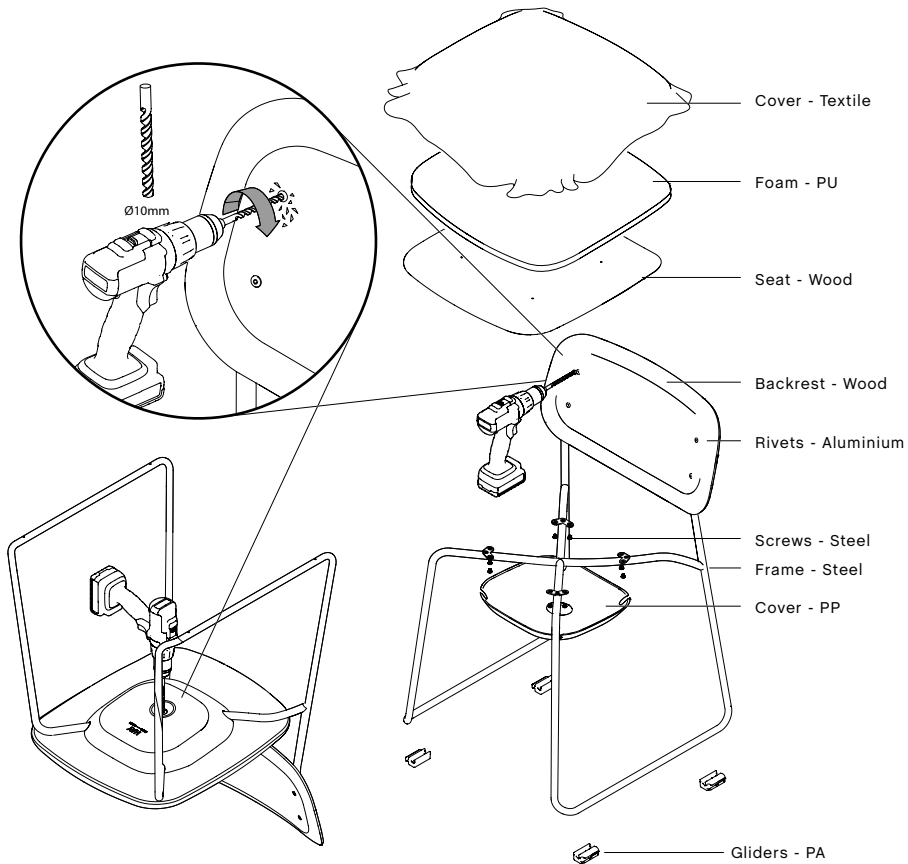

- SOFT EDGE 60 CHAIR -

1. Turn the chair upside down.
2. Remove the cap from the gliders.
3. Unscrew the screw and remove the gliders' receivers.

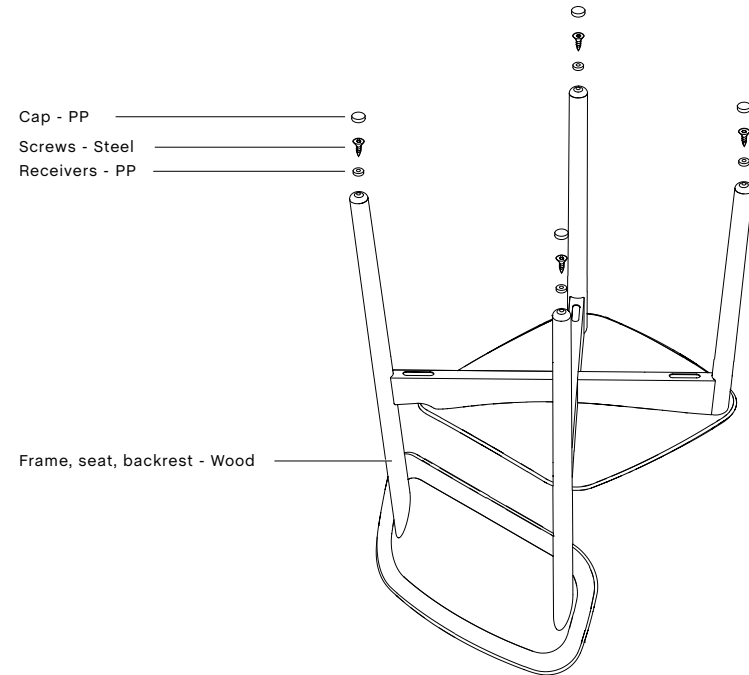

- SOFT EDGE 60 CHAIR WITH UPHOLSTERY -

1. Turn the chair upside down.
2. Remove the cap from the gliders.
3. Unscrew the screw and remove the gliders' receivers.
4. Remove the upholstery and the foam from the wooden shell.

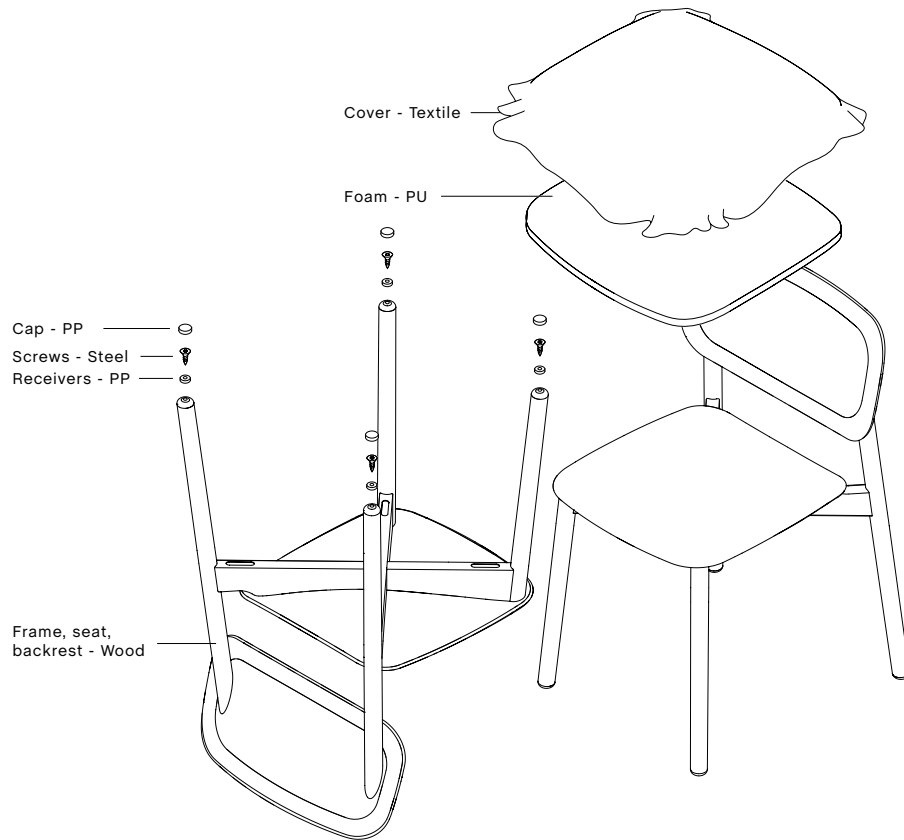

- SOFT EDGE 70 STOOL -

1. Hold the seat while unscrewing the rivets, using a power drill with a 10mm bit.
2. Pull out the gliders from the legs.
3. Turn the chair upside down and drill out the rivets holding the cover.

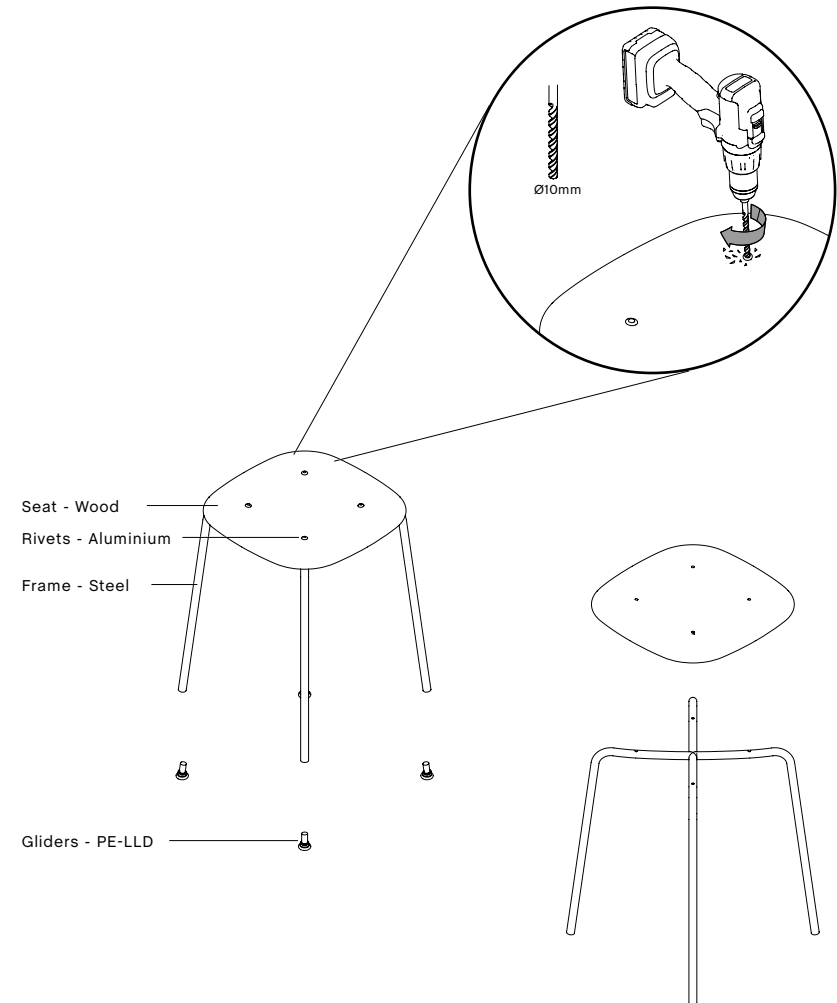

- SOFT EDGE 72 STOOL -

1. Turn the stool upside down.
2. Remove the cap from the gliders.
3. Unscrew the screw and remove the gliders' receivers.

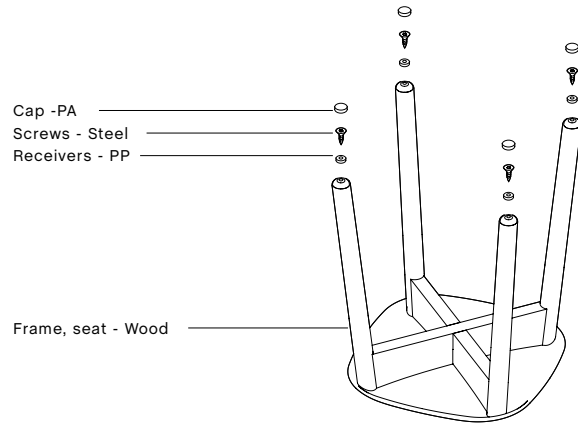

- SOFT EDGE 80 BAR STOOL -

1. Hold the seat while unscrewing the rivets, using a power drill with a 10mm bit.
2. Pull out the gliders from the legs.
3. Turn the stool upside down and drill out the rivets holding the cover.

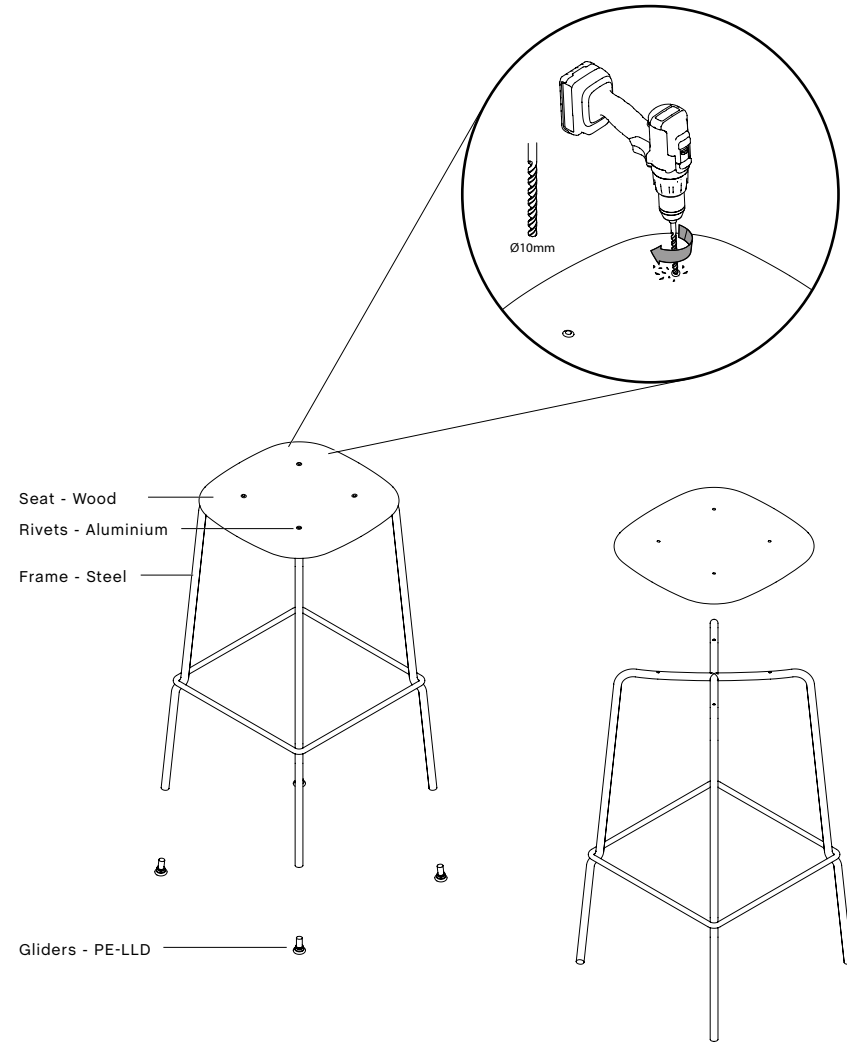

- SOFT EDGE 82 BAR STOOL -

1. Turn the bar stool upside down.
2. Remove the cap from the gliders.
3. Unscrew the screw and remove the gliders' receivers.
4. Unscrew the screws holding the footrest and remove it.

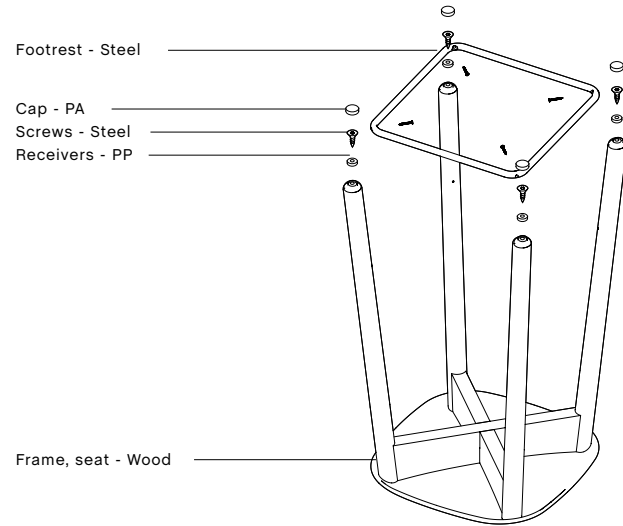

- SOFT EDGE 90 BAR STOOL -

1. Hold the seat and backrest while unscrewing the rivets, using a power drill with a 10mm bit.
2. Pull out the gliders from the legs.
3. Turn the bar stool upside down and drill out the rivets holding the cover.

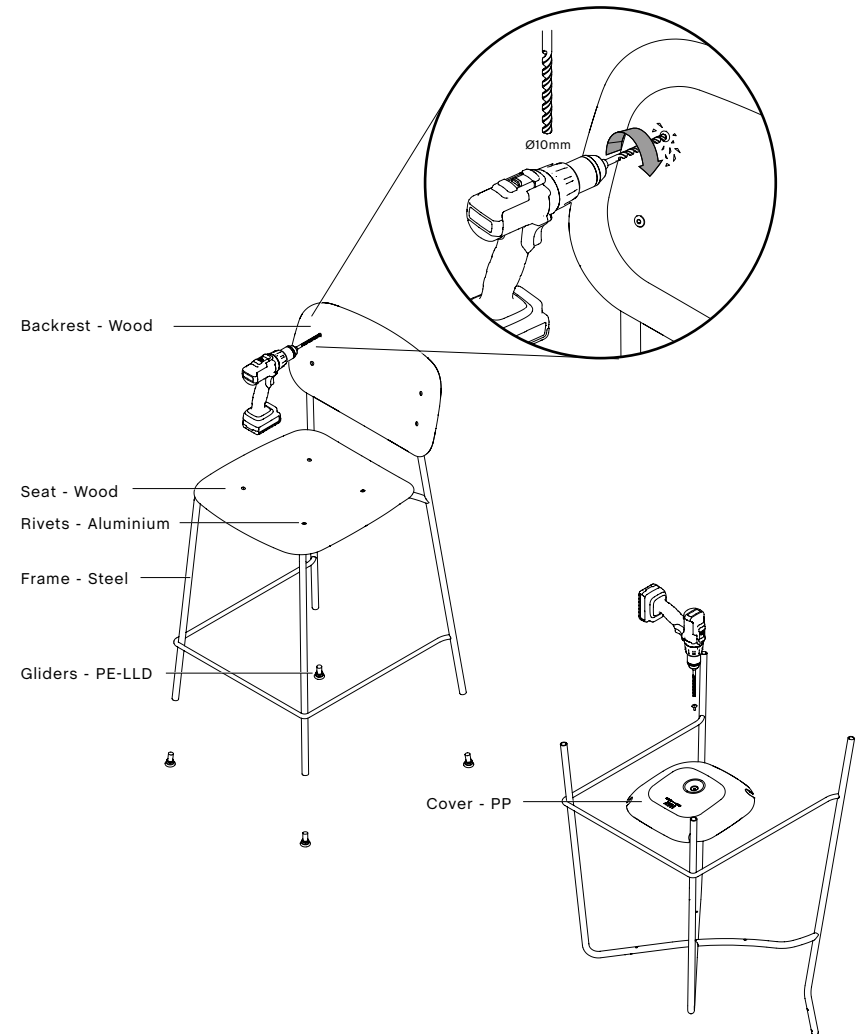

- SOFT EDGE 90 BAR STOOL WITH UPHOLSTERY -

1. Hold the seat and backrest while unscrewing the rivets, using a power drill with a 10mm bit.
2. Pull out the gliders from the legs.
3. Turn the bar stool upside down and drill out the rivets holding the cover.
4. Remove the upholstery and the foam from the wooden shell.

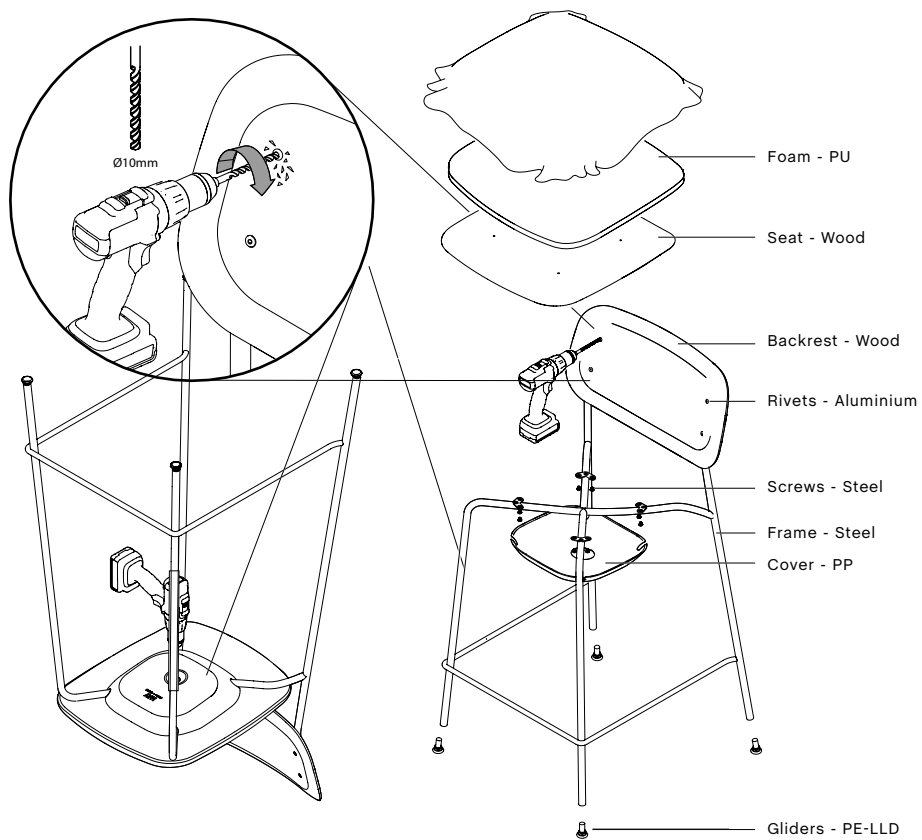

- SOFT EDGE 100 LOUNGE -

1. Hold the seat and backrest while unscrewing the rivets, using a power drill with a 10mm bit.
2. Pull out the gliders from the legs.
3. Turn the chair upside down and drill out the rivets holding the cover.

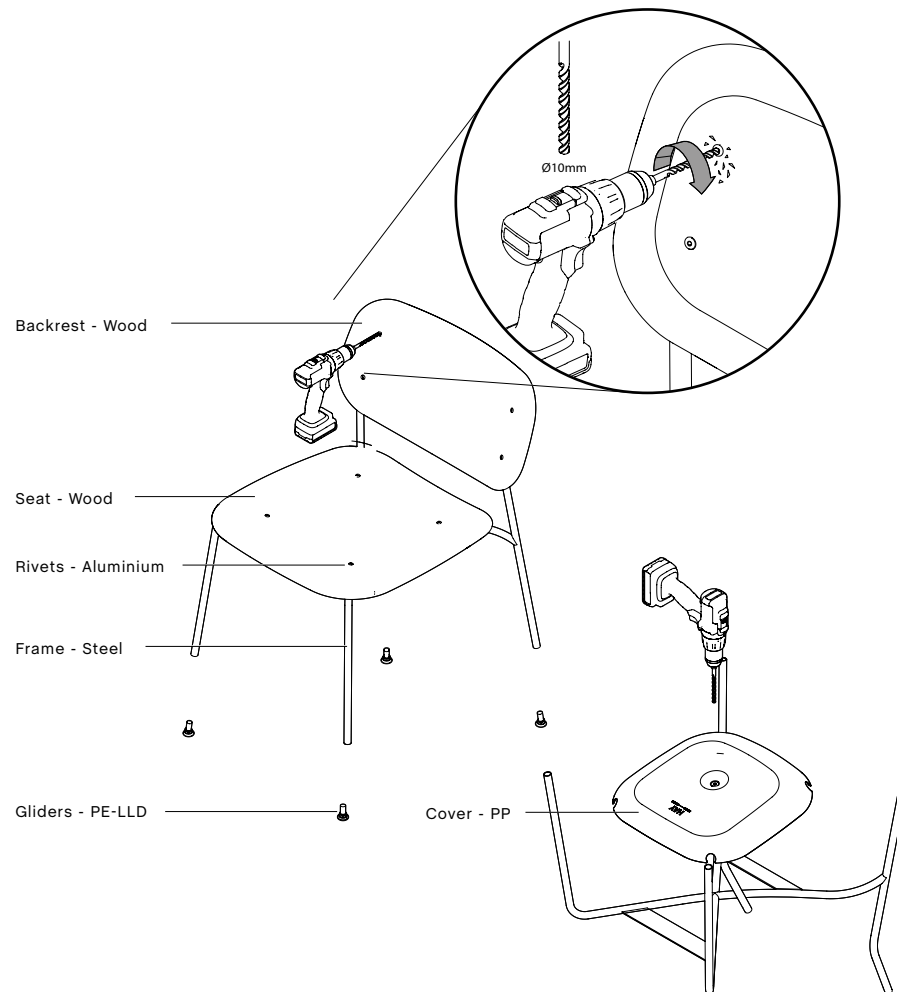

- SOFT EDGE 100 LOUNGE WITH UPHOLSTERY -

1. Hold the seat and backrest while unscrewing the rivets, using a power drill with a 10mm bit.
2. Pull out the gliders from the legs.
3. Turn the chair upside down and drill out the rivets holding the cover.
4. Remove the upholstery and the foam from the wooden shell.

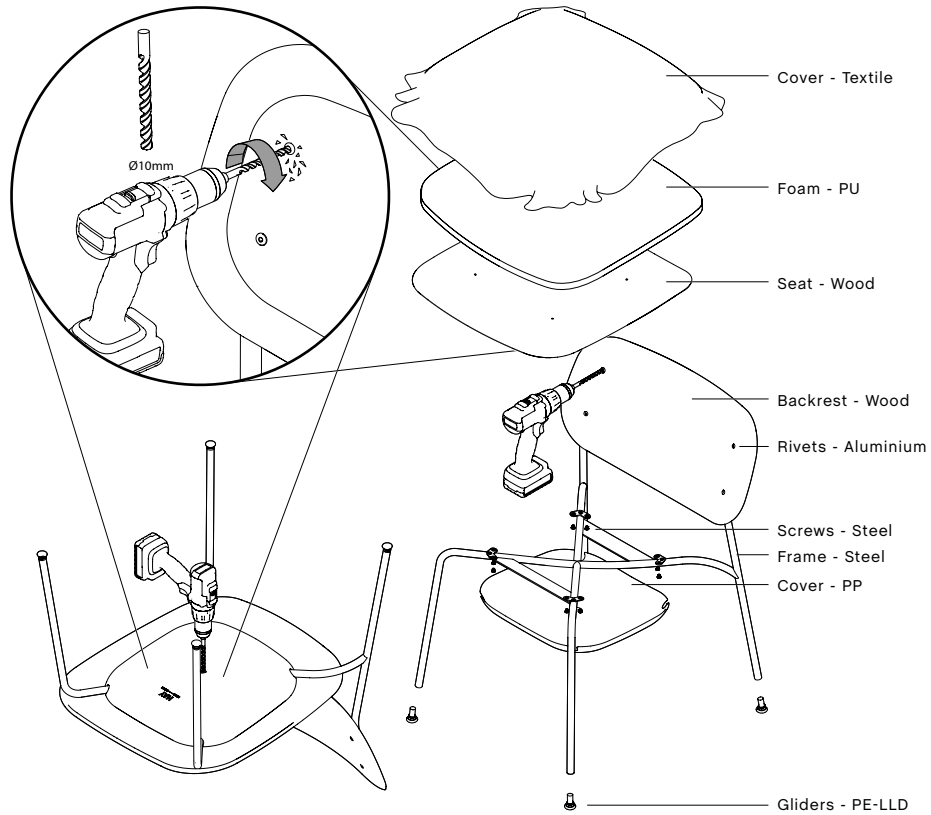

- RESULT CHAIR -

1. Hold the seat and backrest while unscrewing the rivets, using a power drill with a 10mm bit.
2. Remove the bumpers from the backrest posts and the gliders from the legs.

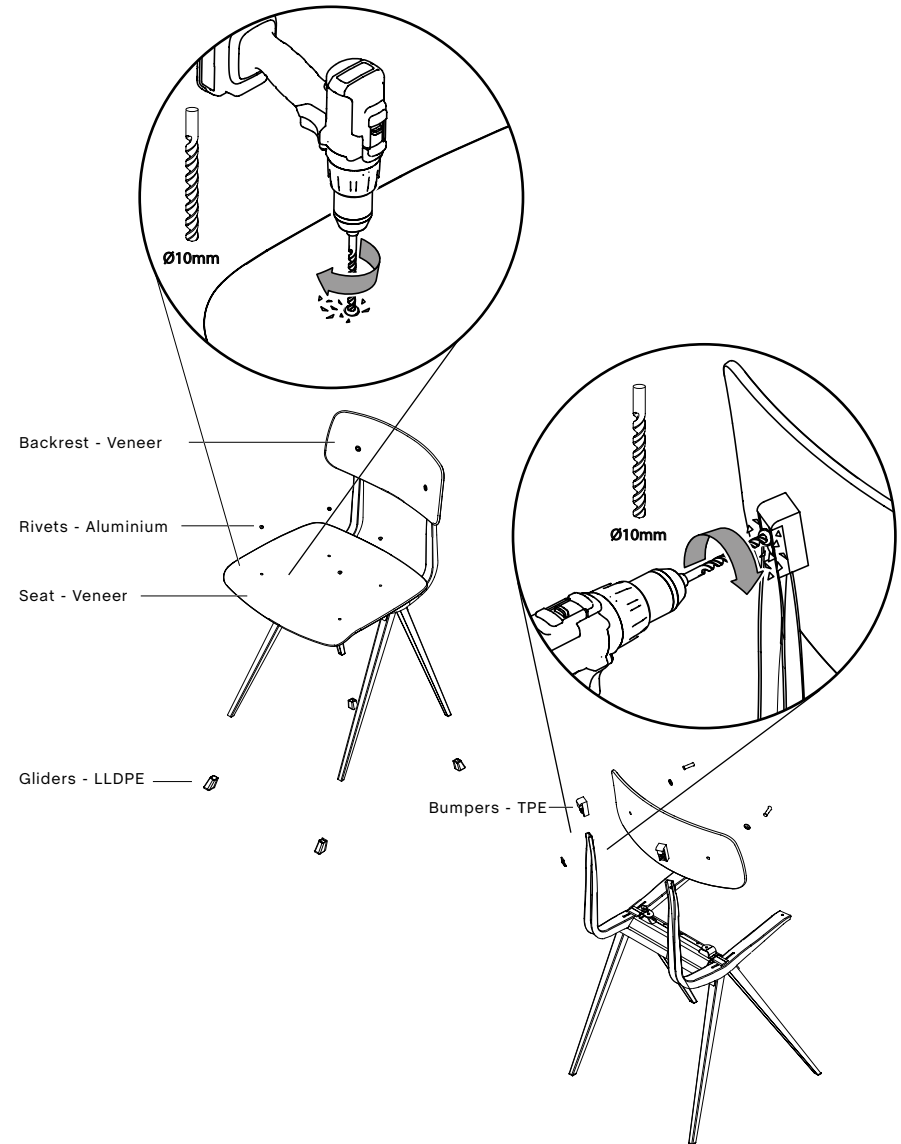

- RESULT CHAIR WITH UPHOLSTERY -

- RESULT ARMCHAIR -

1. Unscrew the screws underneath the seat.
2. Remove the upholstery and the foam from the wooden shell.
3. Hold the seat and backrest while unscrewing the rivets, using a power drill with a 10mm bit.
4. Remove the bumpers from the backrest posts and the gliders from the legs.

1. Hold the seat and backrest while unscrewing the rivets, using a power drill with a 10mm bit.
2. Remove the bumpers from the backrest posts and the gliders from the legs.

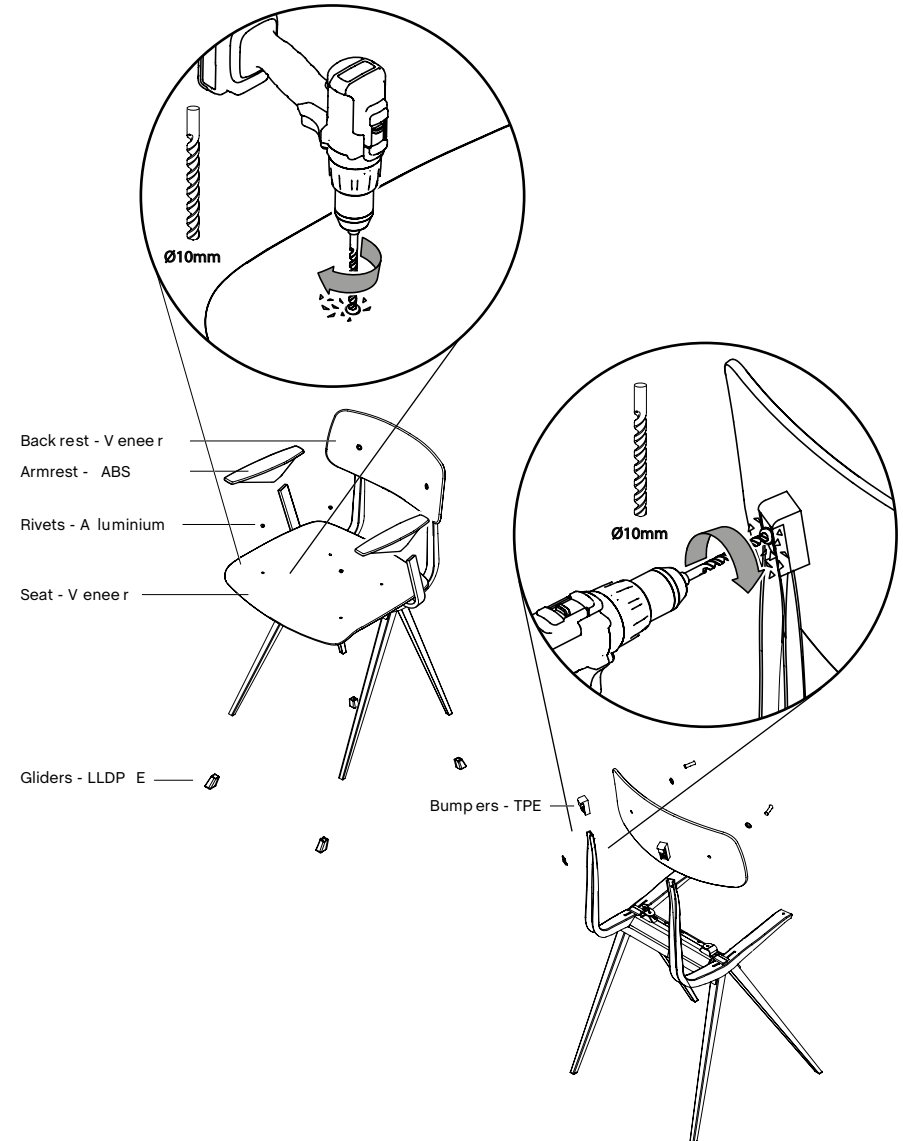
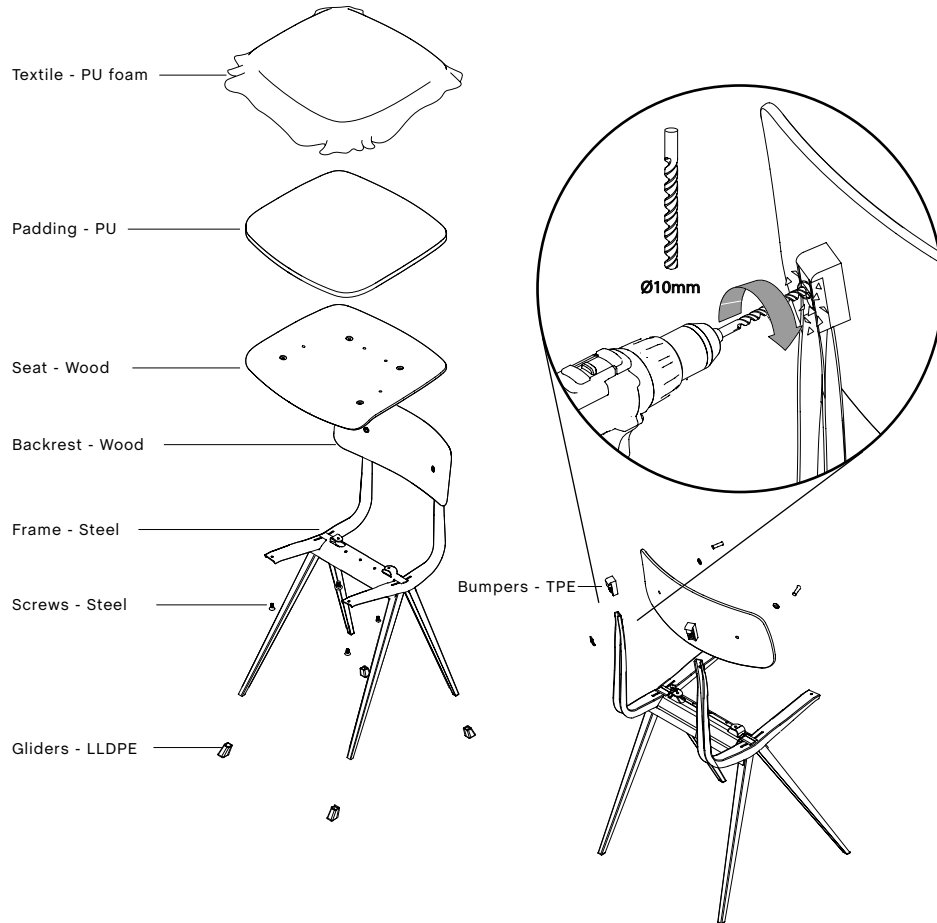

- RESULT ARMCHAIR WITH UPHOLSTERY -

1. Unscrew the screws underneath the seat.
2. Remove the upholstery and the foam from the wooden shell.
3. Hold the seat and backrest while unscrewing the rivets, using a power drill with a 10mm bit.
4. Remove the bumpers from the backrest posts and the gliders from the legs.

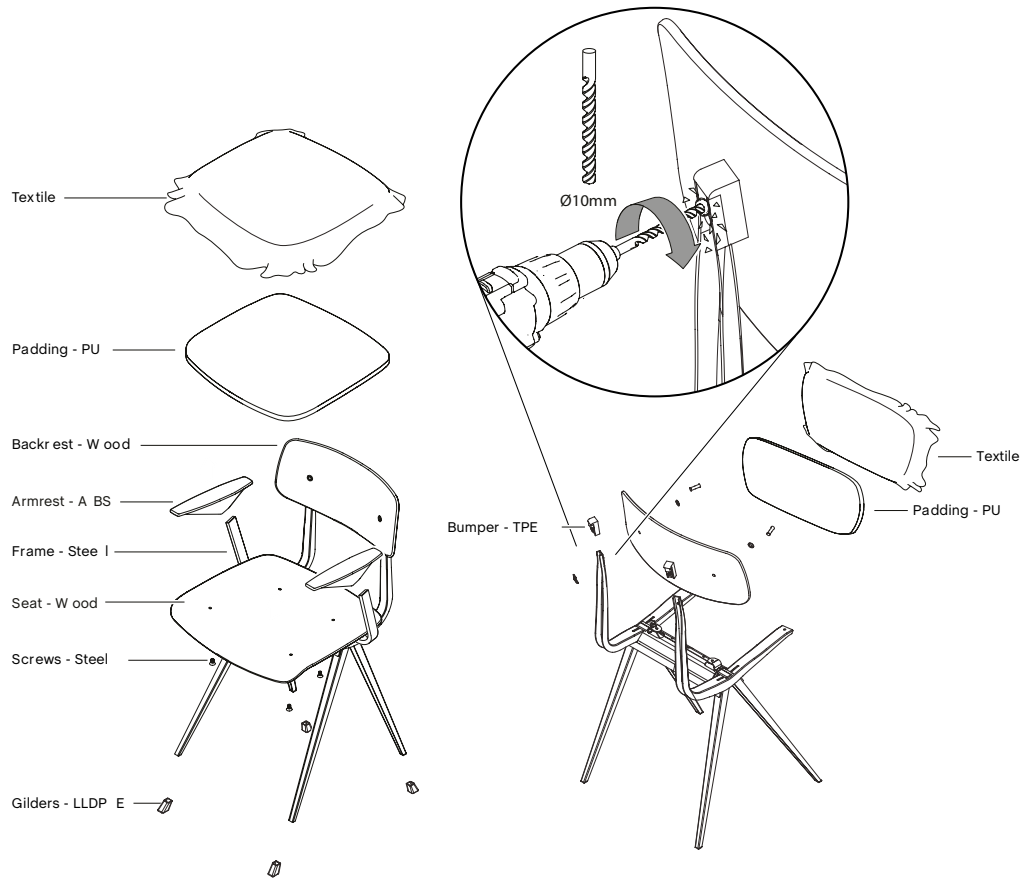

- REVOLT CHAIR -

1. Unscrew the screws holding the seat and backrest.
2. Remove the screws and fittings underneath the seat.
3. Pull the gliders out of the legs.

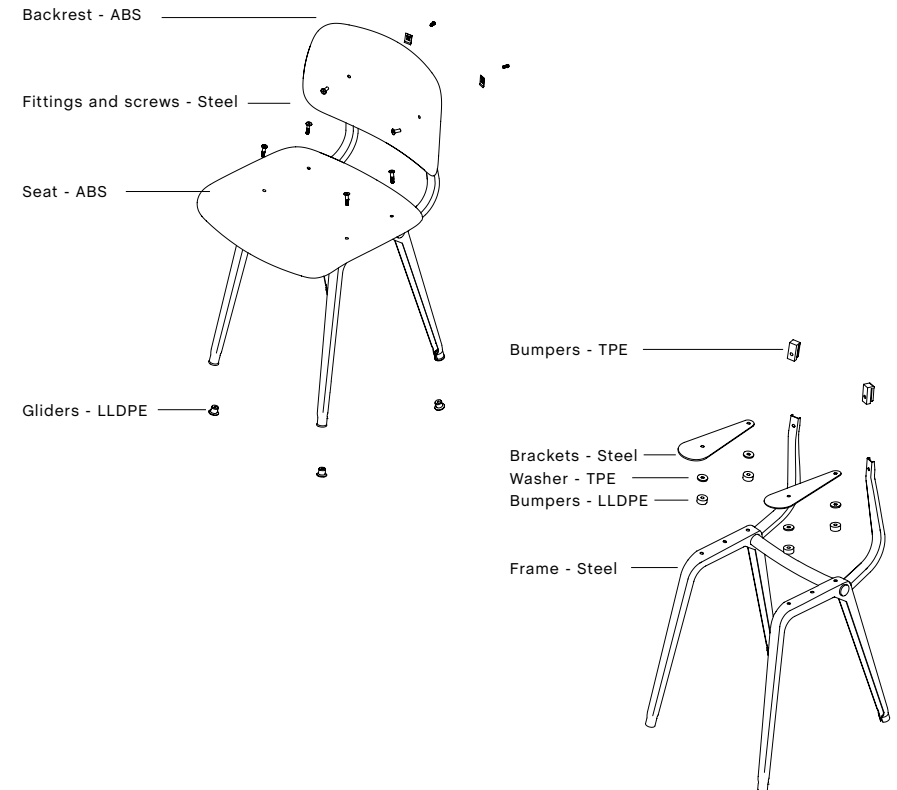

1. Turn the table upside down
2. Unscrew all the screws holding the legs and crossbar.
3. Separate the reinforcement bar from the crossbar by unscrewing the screws.
4. Unscrew the gliders from the legs.

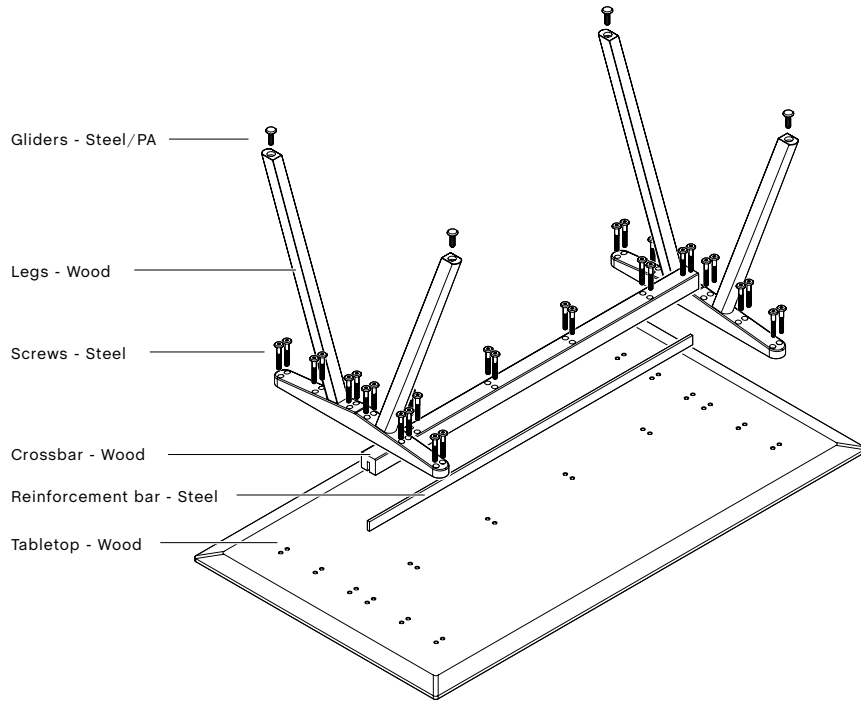

1. Turn the table upside down.
2. Unscrew all the screws holding the legs and crossbar.
3. Unscrew the gliders from the legs.

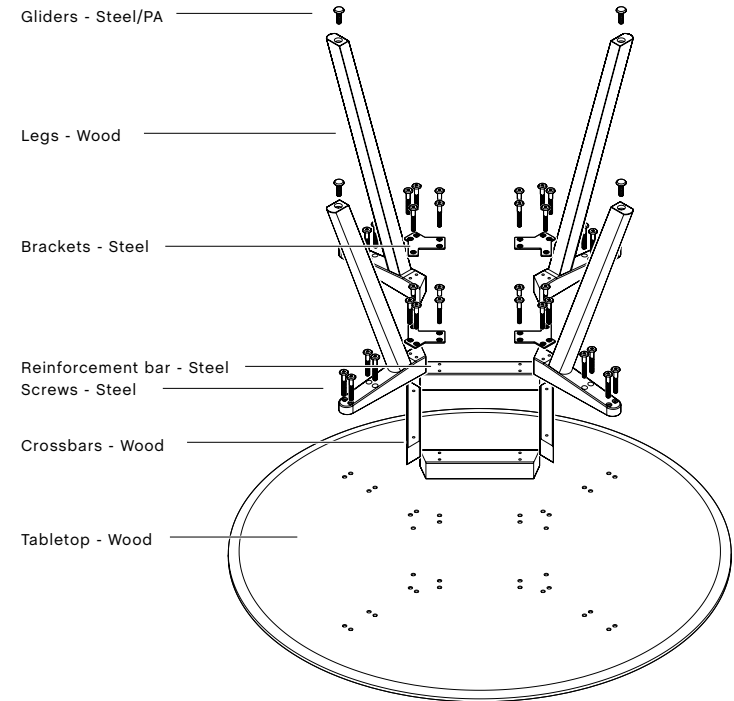

1. Turn the table upside down.
2. Unscrew all the screws holding the legs and crossbar.
3. Separate the reinforcement bar from the crossbar by unscrewing the screws.
4. Unscrew the gliders from the legs.

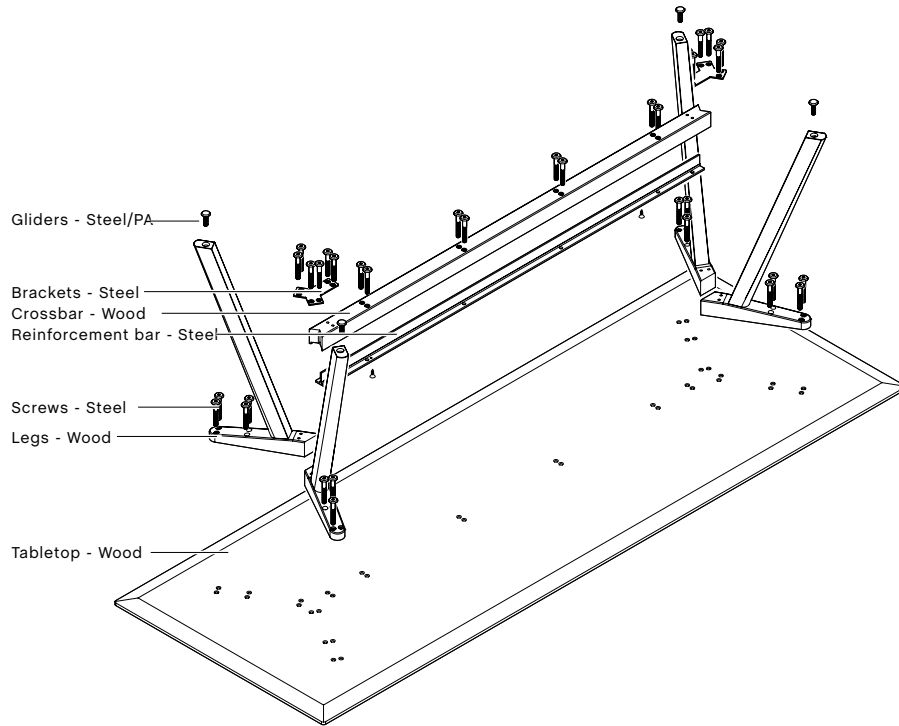

1. Turn the table upside down.
2. Unscrew all the screws holding the legs and crossbar.
3. Separate the reinforcement bar from the crossbar by unscrewing the screws.
4. Unscrew the gliders from the legs.

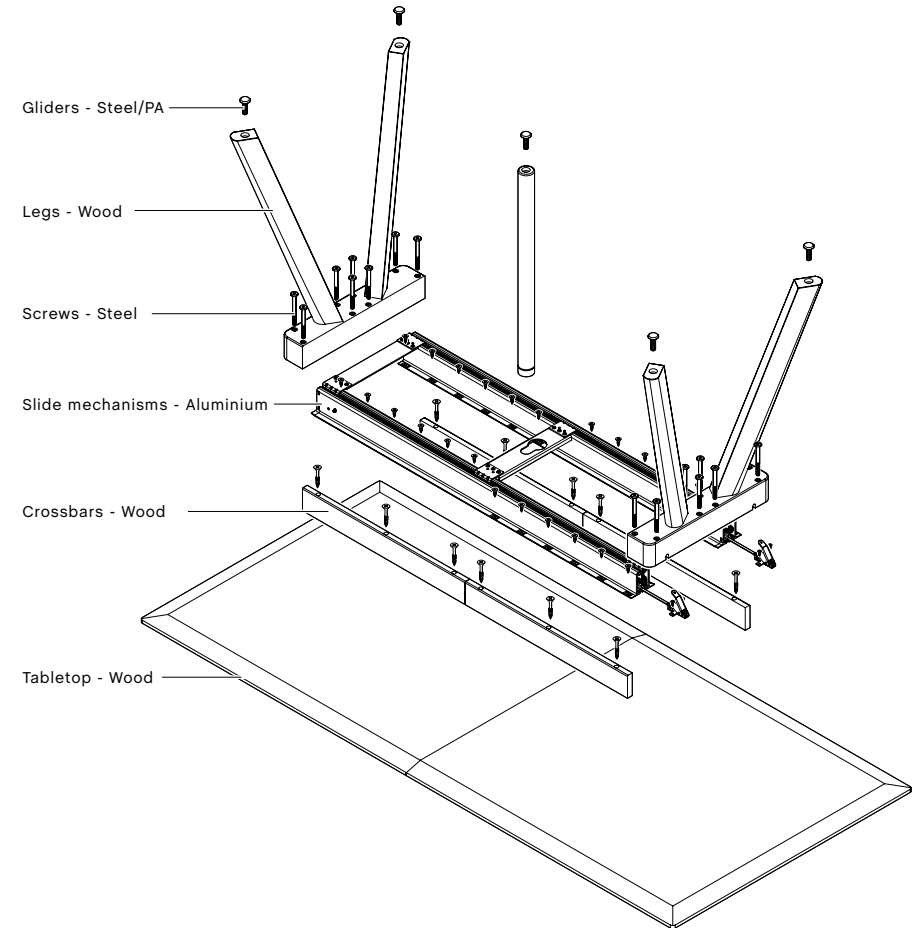

1. Turn the table upside down.
2. Unscrew all the screws holding the legs and crossbar.
3. Unscrew the gliders from the legs.

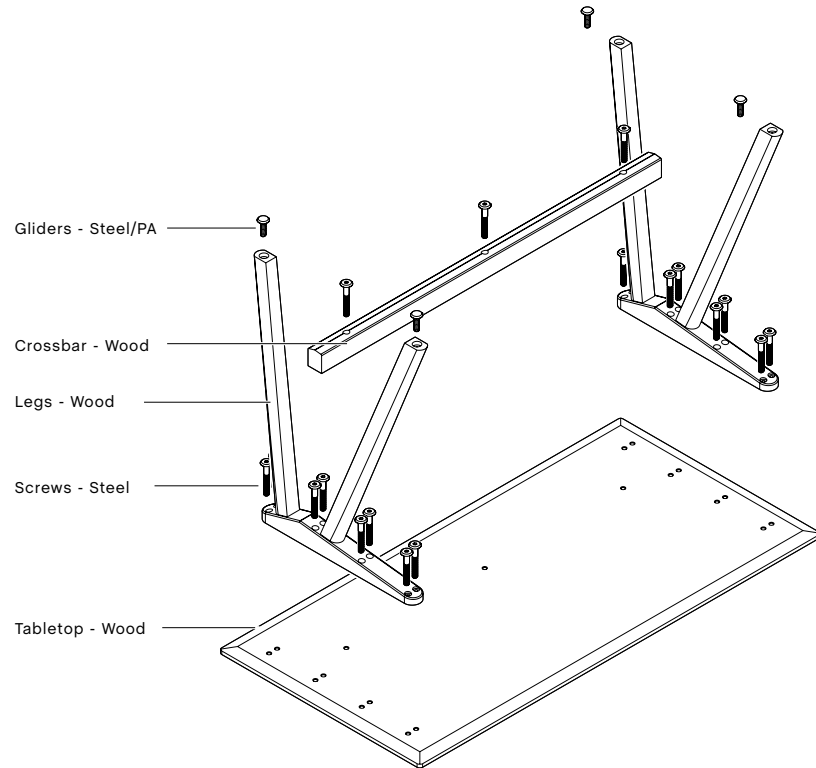

1. Turn the table upside down.
2. Unscrew the gliders from the legs.

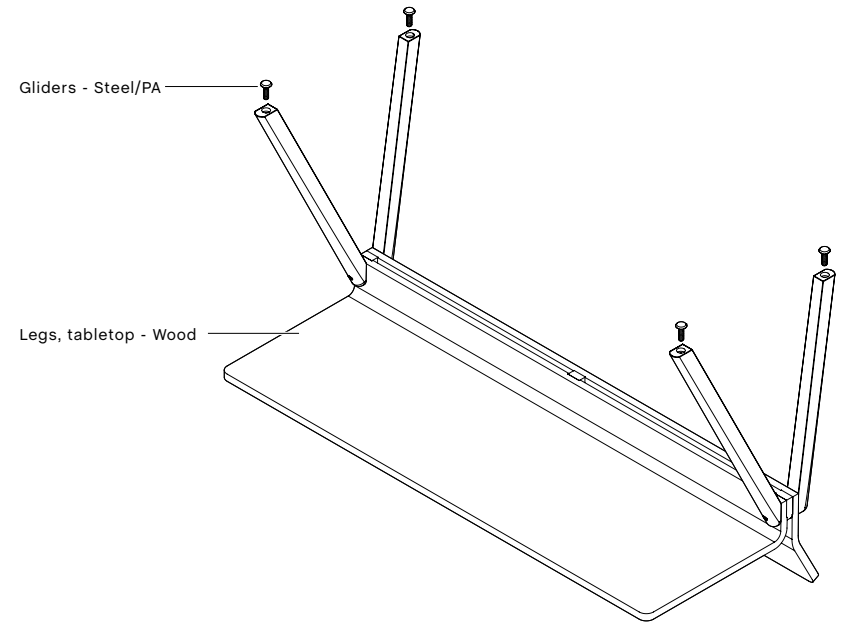

1. Turn the table upside down.
2. Unscrew all the screws holding the legs and crossbar.
3. Unscrew the gliders from the legs.

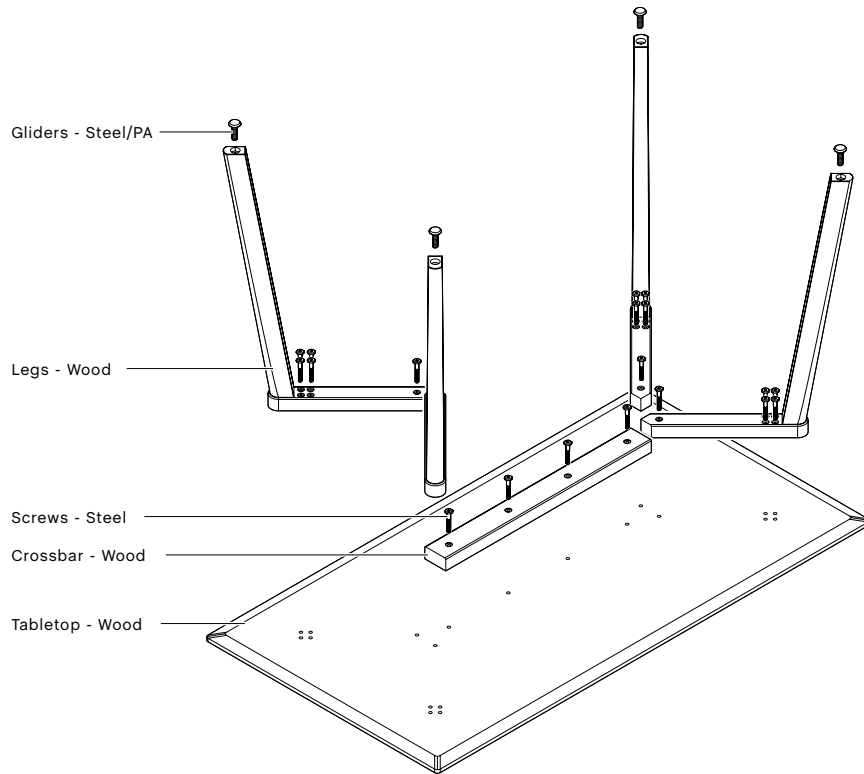

1. Turn the bench upside down.
2. Unscrew all the screws holding the legs and crossbar.
3. Unscrew the gliders from the legs.

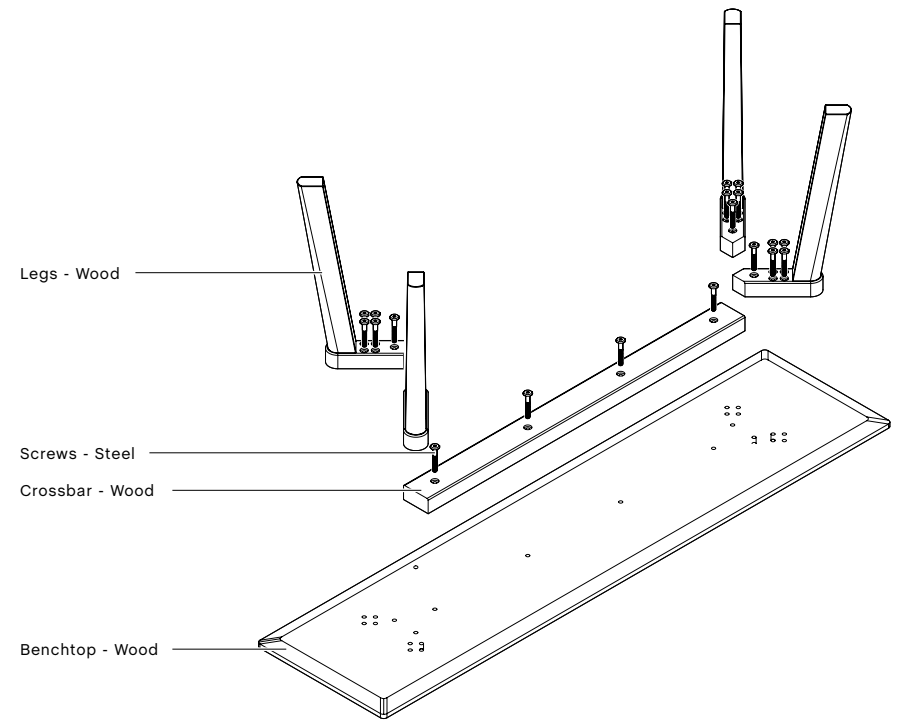

1. Turn the bench upside down.
2. Unscrew all the screws holding the legs and crossbar.
3. Unscrew the gliders from the legs.

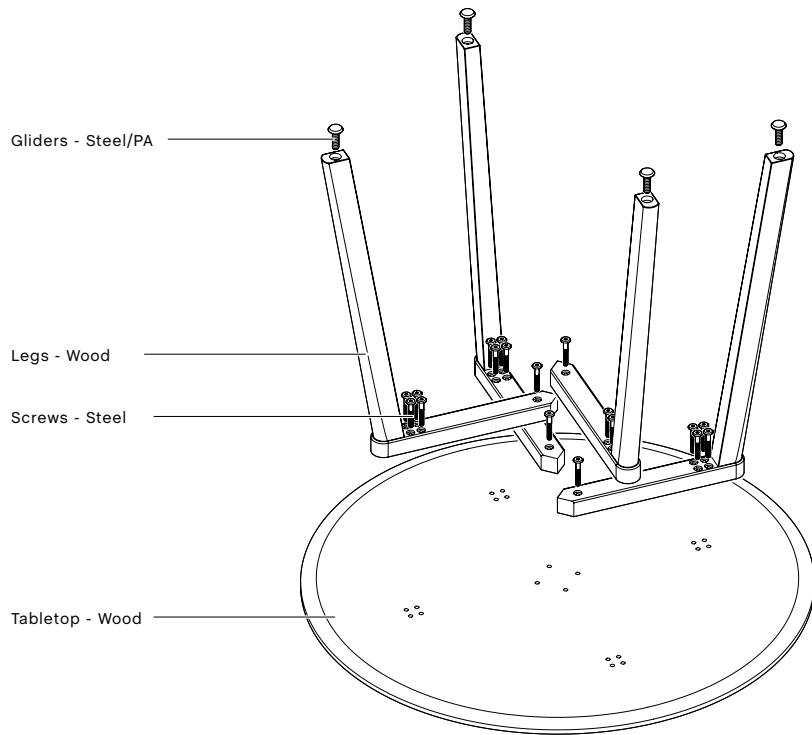

1. Turn the table upside down.
2. Unscrew all the screws holding the legs and crossbar.

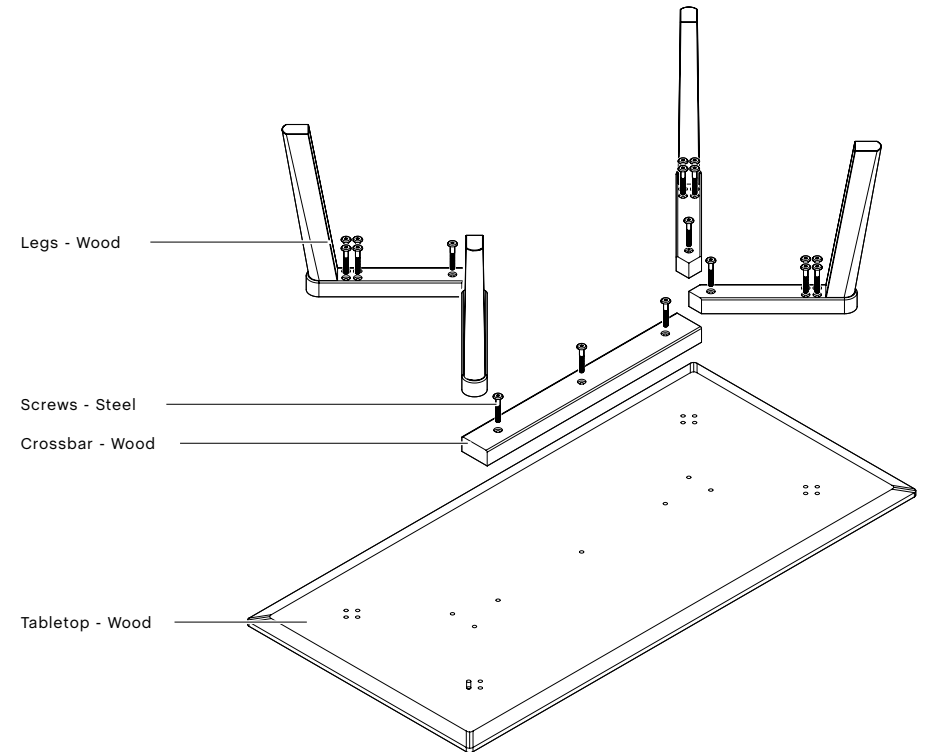

- PASTIS TABLE -

1. Turn the table upside down.
2. Unscrew all the screws holding the legs and column.

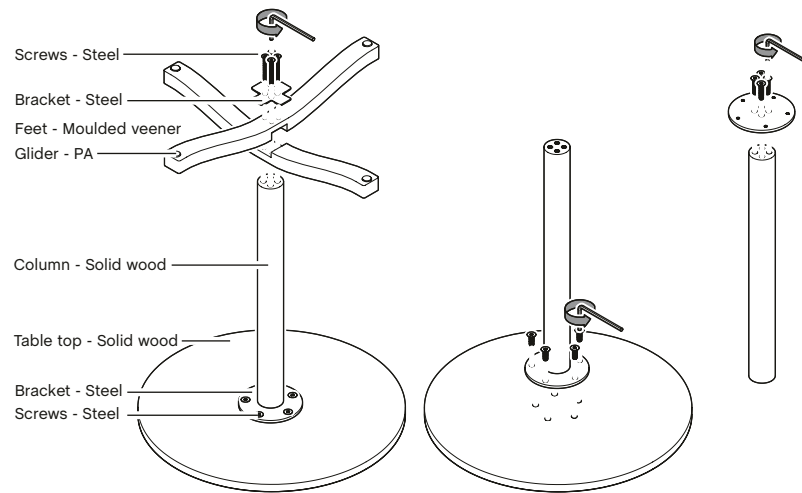

- TRIANGLE LEG BENCH -

1. Turn the bench upside down
2. Unscrew the bolts holding the legs.
3. Unscrew the feet and the tapping screw in the top of the leg.
4. Unscrew all the screws to separate the frame from the bench.
5. Unscrew the screws holding the brackets in each corner.

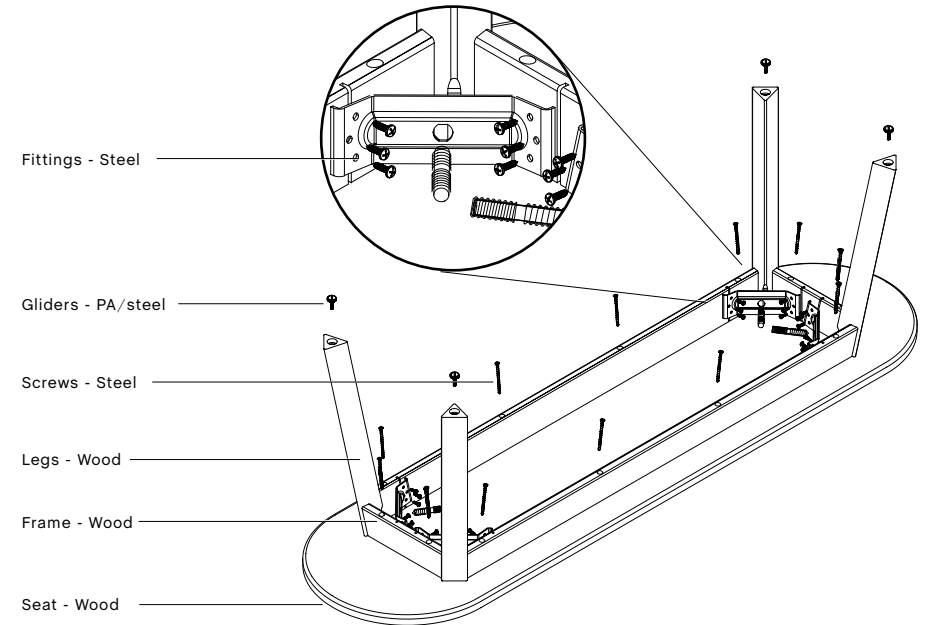

- TRIANGLE LEG TABLE -

1. Turn the table upside down.
2. Unscrew the bolts holding the legs.
3. Unscrew the feet and the tapping screw in the top of the leg.
4. Unscrew all the screws to separate the frame from the table.

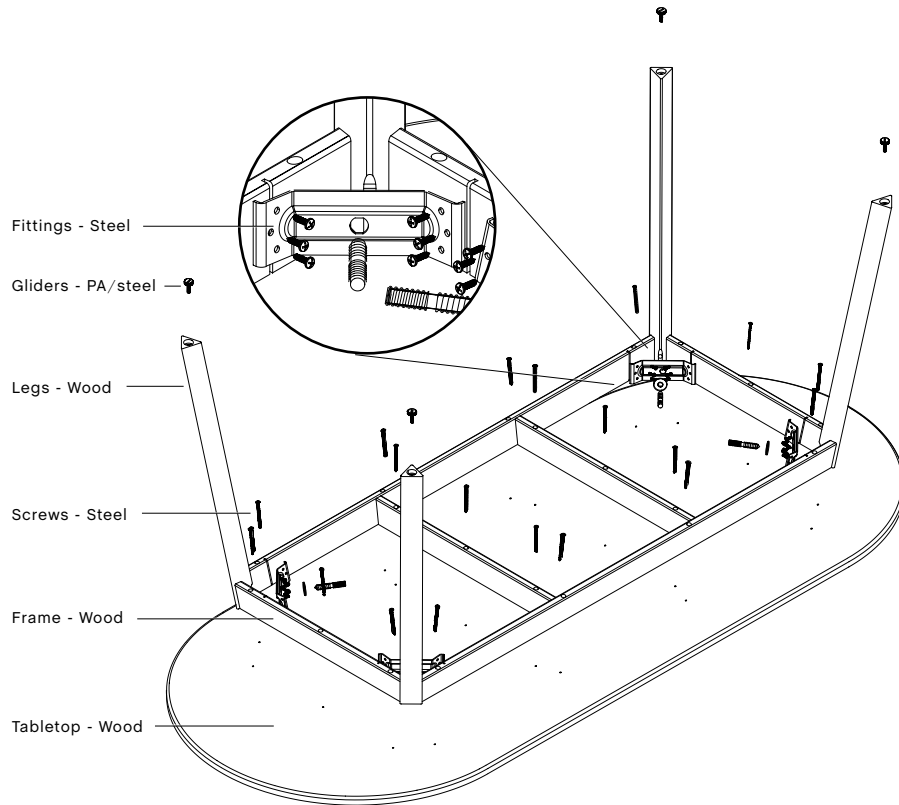

- BOA TABLE -

1. Turn the table upside down.
2. Unscrew all the screws holding the legs and crossbar.
3. Unscrew the gliders from the legs.

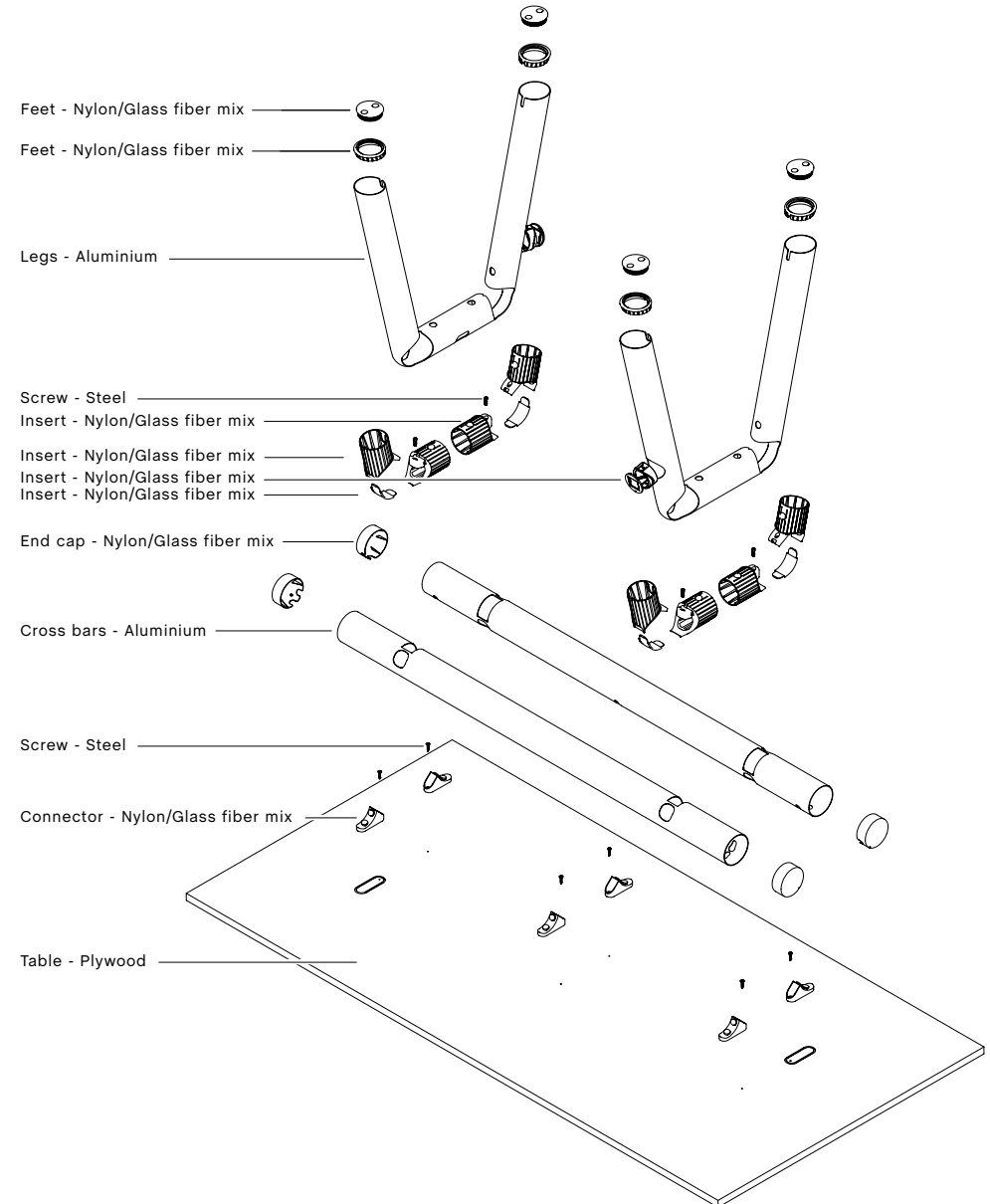

Havnen 1 8700 Horsens Denmark
+45 3164 6000 / hay@hay.com

31/05/2023

HAY